

Airworthiness Directive Schedule

Aeroplanes

Yakovlev/Aerostar 3, 18, 50, 52 and 55 Series

27 October 2016

- Notes**
1. This AD schedule is applicable to Yakovlev/Aerostar 3, 18, 50, 52 and 55 series aircraft which have previously been operated in military service.
 2. This AD schedule includes those National Airworthiness Authority (NAA) ADs applicable to these aircraft.
NAA ADs can be obtained directly from the applicable NAA website.
Links to NAA websites are available on the CAA website at:
<https://www.aviation.govt.nz/aircraft/airworthiness/airworthiness-directives/links-to-state-of-design-airworthiness-directives/>
MPDs can be obtained directly from the UK CAA website at:
<http://www.caa.co.uk/Commercial-Industry/Aircraft/Airworthiness/Continuing-airworthiness/Mandatory-Permit-Directives/>
 3. The date above indicates the amendment date of this schedule.
 4. New or amended ADs are shown with an asterisk *
-

Contents

DCA/YAK/1A	Pneumatic System Isolation – Modification.....	2
DCA/YAK/2	Fabric Covered Control Surfaces – Structural Inspection and Repair.....	2
DCA/YAK/3	Harnesses – Inspection and Rework.....	3
DCA/YAK/4	Undercarriage Uplock Piston Assemblies – Inspection.....	4
DCA/YAK/5	Elevator Control System Pulley – Inspection.....	4
DCA/YAK/6	Cancelled – UK MPD 2002-009R3 refers.....	5
* DCA/YAK/7A	Pneumatic System Reservoirs – Inspection.....	5
DCA/YAK/8	Rear Fuselage Barrier – Installation.....	6
DCA/YAK/9	Rear Cockpit Floor Barrier – Installation.....	7
The State of Design ADs listed below are available directly from the National Airworthiness Authority (NAA) websites. Links to NAA websites are available on the CAA website at https://www.aviation.govt.nz/aircraft/airworthiness/airworthiness-directives/links-to-state-of-design-airworthiness-directives/ If additional NZ ADs need to be issued when an unsafe condition is found to exist in an aircraft or aeronautical product in NZ, they will be added to the list below.		
UK MPD 2002-009R3	Airframe Life Limitation.....	8

DCA/YAK/1A Pneumatic System Isolation – Modification

Applicability: Yakovlev 52 series aircraft, all S/N.

Note 1: The requirement in DCA/YAK/1A revised to introduce an approved equivalent modification. This AD is prompted by overseas reports of brake system failures which resulted in accident damage to the aircraft, damage to other parked aircraft and airfield fixtures. It is possible to start the engine with the pneumatic system inadvertently switched off. The pneumatic energy stored in downstream systems (in the undercarriage, the flaps and the brakes) is sufficient to start the engine which could result in an inoperable braking system.

Requirement: To prevent brake system failure modify the pneumatic system per the instructions in Aerostar SB 7/1995 or embody an approved equivalent modification (FSL 2926 Ignition Switch Isolation is an equivalent modification).

Note 2: Aerostar SB No. 7/1995 introduces a modification which isolates the downstream pneumatic system.
A copy of Aerostar SB 7/1995 and the parts required for this modification can be obtained from YAK UK Ltd at: <http://www.yakuk.com/>
(UK CAA MPD 1997-009 refers)

Compliance: By 28 February 2014, unless previously accomplished.

Effective Date: DCA/YAK/1 - 29 March 2012
DCA/YAK/1A - 30 January 2014

DCA/YAK/2 Fabric Covered Control Surfaces – Structural Inspection and Repair

Applicability: Yakovlev 50 and 52 series aircraft, all S/N.

Requirement: To prevent failure of control surfaces due to possible corroded or poorly repaired internal structure, accomplish the following:

Inspect the internal structure of fabric covered control surfaces for corrosion and poor repairs with the aid of a borescope inspection method.

The internal structure access method must be in accordance with relevant aircraft manufacturer requirements, or in accordance with an acceptable method.

If any defects are found, repair the internal structure as required, before further flight.

Note: It may be possible to gain access to the internal structure of fabric covered control surfaces through the root end of the control surface, or through purpose made inspection holes and patches in the control surface fabric.

(UK MPD 1997-019R2 refers)

Compliance: Within the next 36 months or 1500 hours TIS whichever occurs sooner, unless previously accomplished in the last 36 months or 1500 hours TIS, and thereafter at intervals not to exceed 36 months or 1500 hours TIS whichever occurs sooner.

Effective Date: 29 March 2012

DCA/YAK/3 Harnesses – Inspection and Rework

Applicability: Yakovlev 50 and 52 series aircraft, all S/N fitted with a 'ball-latch' harness, and Yakovlev 50 and 52 series aircraft, all S/N fitted with a thumb operated handbrake locking latch on the rear of the control column.

Note 1: This AD is prompted by overseas reports of the early "ball-latch" harness mechanisms failing under load. On aircraft fitted with 'cone-latch' harness and a thumb operated handbrake locking latch on the rear of the control column, the handbrake locking latch can foul the 'cone-latch' harness.

Requirement: To prevent failure of harnesses under load, or inadvertant fouling of the 'cone-latch' harness by the thumb operated handbrake locking latch on the rear of the control column, accomplish the following:

1. For all Yak 50 and 52 aircraft:

Determine the type of harness latching mechanism fitted to the aircraft.

If an early "ball-latch" harness is found fitted, replace with 'cone-latch' harness or with an equivalent acceptable harness.

2. For all Yak 50 aircraft fitted with 'cone-latch' harnesses:

Determine if the aircraft is fitted with a thumb operated handbrake locking latch on the rear of the control column.

If a thumb operated handbrake locking latch is found fitted, remove the locking latch, or alternatively embody control column modification 53-U (53-Y).

3. For Yak 52 aircraft, S/N 780102 through to 8910115 fitted with 'cone-latch' harnesses:

Determine if the aircraft is fitted with a thumb operated handbrake locking latch on the rear of the control column.

If a thumb operated handbrake locking latch is found fitted, remove the locking latch, or alternatively embody control column modification 53-U (53-Y).

Note 2: The safety harnesses of any unoccupied seat should be latched before flight to prevent fouling of the control column in flight.

(UK MPD 1997-020R1 refers)

Compliance:

1. By 29 September 2012.
2. By 29 September 2012.
3. By 29 September 2012.

Effective Date: 29 March 2012

DCA/YAK/4 Undercarriage Uplock Piston Assemblies – Inspection

Note 1: This AD is prompted due to the uplock piston assembly in both the nose wheel and main undercarriage pneumatic circuits being prone to accumulation of dirt and moisture, which can cause corrosion. In addition the deterioration of the rubber seals, due to a lack of lubrication has been noted. An overseas occurrence where corrosion prevented the up-lock catch releasing, resulted in a wheels up landing.

Applicability: Yakovlev 3, C.11, 18 and 52 series aircraft, all S/N.

Requirement: To prevent failure of an undercarriage uplock piston assembly, which could result in a wheels up landing, accomplish the following:

Remove the uplock piston assembly (Yak 52 P/N 524705-30) in both the nose wheel and main undercarriage pneumatic circuits.

Dismantle and internally inspect for corrosion in the piston and cylinder. Replace defective parts if corrosion is found. Inspect the seals and replace, as required, and lubricated rubber parts with appropriate rubber grease.

Note 2: If the requirements of this AD are included in the approved maintenance programme, then compliance with the maintenance programme is acceptable to comply with the requirements of this AD.

(UK MPD 1998-016R2 refers)

Compliance: Within the next 50 hours TIS unless previously accomplished in the last 200 hours TIS, and thereafter at intervals not to exceed 200 hours TIS.

Effective Date: 29 March 2012

DCA/YAK/5 Elevator Control System Pulley – Inspection

Applicability: Yakovlev 52 series aircraft, all S/N.

Note: This AD is prompted by a report of finding a 19 mm crack in the elevator control pulley P/N 525100-80-3 (referred to in the Romanian parts catalogue as a “lever”). The failure of this component could result in loss of elevator control.

Requirement: To prevent failure of the elevator balance weight flange/sector/lever P/N 525100-80-3 which could result in loss of elevator control, accomplish the following:

Inspect lever P/N 525100-80-3 for cracks using a dye penetrant method. Inspect in the area below the attachment of the balance weight bracket at the point where the section reduces from 10 mm to 7 mm.

If the lever is found cracked, replace affected parts before further flight.

Inspect the primary stops of the lever for damage and wear. If any defects are found, or if the rubber pads are excessively worn, replace affected parts before further flight.

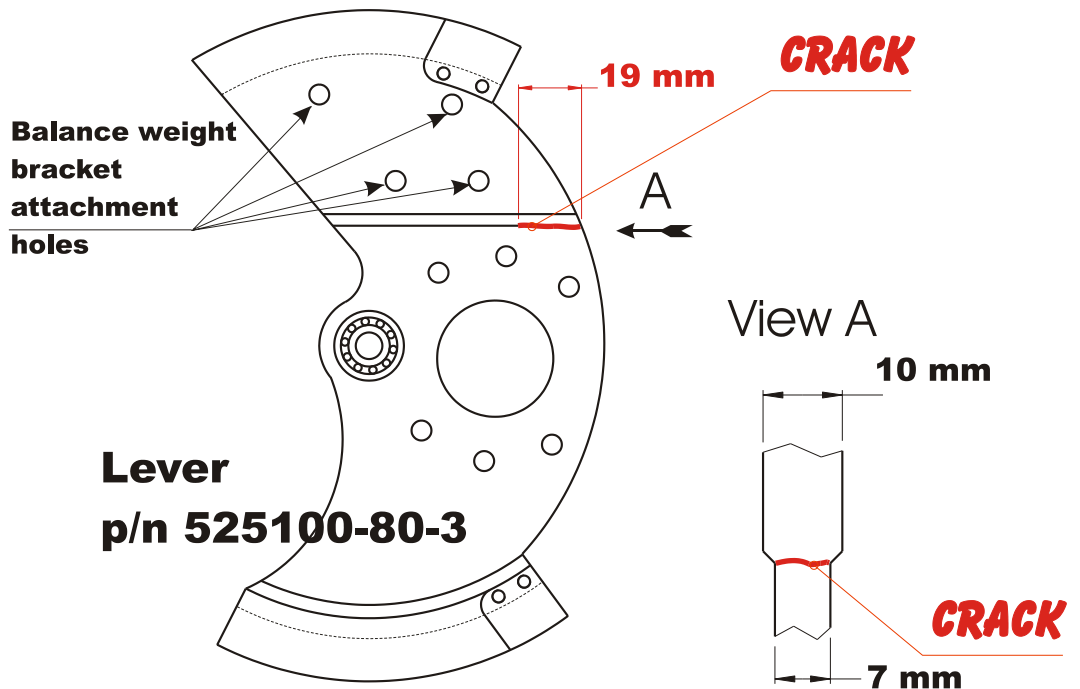

(UK MPD 2000-004 refers)

Compliance: Within the next 50 hours TIS or the next maintenance inspection whichever occurs sooner, unless previously accomplished in the last 100 hours or 12 months, and thereafter at intervals not to exceed 100 hours TIS or 12 months whichever occurs sooner.

Effective Date: 29 March 2012

DCA/YAK/6 Cancelled – UK MPD 2002-009R3 refers

Effective Date: 20 March 2014

*** DCA/YAK/7A Pneumatic System Reservoirs – Inspection**

Applicability: Yakovlev C.11, C.18A, 50, 52, 55 and 55M series aircraft, all S/N.

Note 1: This AD revised to remove the x-ray inspection requirement.

Requirement: To prevent failure of the pneumatic system reservoir due to possible corrosion which could result in serious structural damage and loss of aircraft control, accomplish the following:

1. After every flight:

Open the water trap of the pneumatic system reservoir and drain the accumulated water.

2. At intervals not to exceed 50 hours TIS or annually, whichever occurs sooner:

Remove the pneumatic system reservoir from the aircraft and drain the water.

3. At every annual inspection:

Remove the pneumatic system reservoir from the aircraft and clean the interior of the reservoir using a suitable method. Accomplish a detailed visual inspection of the internal surfaces of the reservoir with the aid of a borescope or similar inspection method. Light surface corrosion is acceptable. For all other corrosion, typically severe corrosion, pitting, exfoliation or any signs of distress, replace the reservoir before further flight.

4. At intervals not to exceed 60 months, or at the interval recommended by the aircraft manufacturer, whichever occurs sooner:

Accomplish a hydrostatic test of the pneumatic system reservoir per the manufacturer instructions, or per industry best practice for the testing of pneumatic system pressure vessels (typically 1.5 times working pressure). If the reservoir fails to hold the test pressure, or shows any signs of distress/distortion, replace the reservoir before further flight.

Note 2: If requirement 1 of this AD is included in the approved preflight inspection, then compliance with the approved preflight inspection is acceptable to comply with requirement 1 of this AD. Alternatively, requirement 1 of this AD may be accomplished by adding the inspection requirement to the tech log. Requirement 1 may be performed and certified under the provision in Part 43 Appendix A.1 (7) by the holder of a current pilot licence, if that person is rated on the aircraft, appropriately trained and authorised (Part 43, Subpart B refers), and the maintenance is recorded and certified as required by Part 43.

Note 3: If the requirements of this AD are included in the approved maintenance programme, then compliance with the maintenance programme is acceptable to comply with the requirements of this AD.

Note 4: The CAA is not aware of a corrosion inhibiting compound recommended by the aircraft manufacturer for use in the pneumatic reservoir or system. Operators/maintainer are reminded if they choose to use proprietary corrosion inhibiting compounds it is their responsibility to ascertain and technically justify the fitness for purpose of the compound they use.

(UK MPD 2004-004R1 refers)

Compliance: From 29 March 2012 (the effective date of DCA/YAK/7).

Effective Date: DCA/YAK/7 - 29 March 2012
DCA/YAK/7A - 27 October 2016

DCA/YAK/8 Rear Fuselage Barrier – Installation

Applicability: Yakovlev Yak 52 aircraft, all S/N.

Note 1: This AD introduces two barriers in the rear fuselage of the aircraft to close off the aft elevator quadrant from the cockpit area.

Requirement: To prevent loose articles migrating to the rear of the aircraft fuselage which could jam the aft elevator control, accomplish the following:

1. Install a barrier across the aft most fuselage frame opening. This frame is located aft of the flux detector and is accessible through the flux detector panel on the rear LH side of the fuselage beneath the tailplane. This barrier must cover the frame opening. The hole in the barrier to allow for the elevator control cable must be as small as possible. Before this fuselage barrier is installed, the enclosed areas behind the barrier must be thoroughly inspected for the presence of FOD.

Thoroughly inspect the area behind the aft most fuselage frame for the presence of FOD before installing the fuselage barrier.

2. Install a barrier across the upper two lightening holes in the rear fuselage forward tailplane attachment bulkhead. The hole in the barrier to allow for the elevator trim cables must be as small as possible.

Thoroughly inspect the area behind the rear fuselage forward tailplane attachment bulkhead for the presence of FOD before installing the fuselage barrier.

3. Revise the aircraft approved maintenance programme to include a requirement for the enclosed area behind the aft barrier to be inspected whenever the tailplane to fin fairing is removed, and at every annual maintenance inspection. This inspection may require the removal of the barrier if the inspection cannot be carried out by other means.

Note 2: Before any fuselage barriers are installed on the aircraft the enclosed areas behind the barriers (fore and aft of all fuselage frames) must be thoroughly inspected for the presence of FOD.

Note 3: The barriers must be installed under a modification using suitable aerospace fabric or an alternate equivalent acceptable material. Fuselage barrier modification Yak/61 satisfies the requirements of this AD.

The required parts for this modification can be obtained from Yak UK Ltd at <http://www.yakuk.com/>

(NZ Occurrence 12/218 and UK MPD 2004-006 refer)

Compliance:

1. By 29 June 2012.
2. By 29 June 2012.
3. By 29 June 2012.

Effective Date: 29 March 2012

DCA/YAK/9 Rear Cockpit Floor Barrier – Installation

Applicability: Yakovlev Yak 52 aircraft, all S/N.

Note 1: The investigation of a fatal Yak 52 accident overseas determined that it was possibly caused by a restriction in the flight controls. The most likely cause of the restriction was the buckle on the unsecured crotch strap of the rear cockpit occupant which became jammed in the flight controls.

Requirement: To prevent an unsecured harness in the rear cockpit possibly jamming the flight controls, accomplish the following:

1. Install a barrier on the rear cockpit floor to prevent loose articles jamming the elevator and aileron controls. This barrier must be positioned to cover the bay on the centreline immediately aft of the attachment point for the crotch strap. Longitudinally this bay extends aft to the next fuselage frame and laterally it extends between the two angles running fore and aft either side of the flight control rod.

Before installing the floor barrier thoroughly inspect the area below the rear cockpit floor for the presence of FOD.

2. Revise the aircraft approved maintenance programme to include a requirement for the area under the barrier to be inspected at every annual inspection. The barrier should be readily removable for this purpose.

Note 2: Before the cockpit floor barrier is installed on the aircraft the enclosed areas behind the barrier (below the floor in the area of the elevator and aileron controls) must be thoroughly inspected for the presence of FOD.

Note 3: The barrier must be installed under a modification using a suitable aerospace fabric or an alternate equivalent material. It is expected that the barrier will be metallic although alternate acceptable materials may be used.

Note 4: The safety harnesses of any unoccupied seat should be latched before flight to prevent fouling of the flight controls in flight.

(NZ Occurrence 12/218 and UK MPD 2008-005R1 refer)

Compliance:

1. By 29 June 2012.
2. By 29 June 2012.

Effective Date: 29 March 2012

The State of Design ADs listed below are available directly from the National Airworthiness Authority (NAA) websites. Links to NAA websites are available on the CAA website at <https://www.aviation.govt.nz/aircraft/airworthiness/airworthiness-directives/links-to-state-of-design-airworthiness-directives/>

If additional NZ ADs need to be issued when an unsafe condition is found to exist in an aircraft or aeronautical product in NZ, they will be added to the list below.

UK MPD 2002-009R3 Airframe Life Limitation

Applicability: Yakovlev Yak-50 aircraft.

Effective Date: 20 March 2014