

Airworthiness Directive Schedule

Helicopters

Airbus Helicopters AS 350 Series

27 March 2025

- Notes:**
1. This AD schedule is applicable to Airbus Helicopters AS 350 series manufactured under Type Certificate Numbers:

Aircraft Model:	Type Certificate Number:
AS 350B	EASA R.008 (formerly DGAC 157)
AS 350B1	EASA R.008 (formerly DGAC 157)
AS 350B2	EASA R.008 (formerly DGAC 157)
AS 350BA	EASA R.008 (formerly DGAC 157)
AS 350BB	EASA R.008 (formerly DGAC 157)
AS 350B3	EASA R.008 (formerly DGAC 157)
AS 350D	FAA H9EU

2. The European Union Aviation Safety Agency (EASA) is the National Airworthiness Authority (NAA) responsible for the issue of State of Design Airworthiness Directives (ADs) for these helicopters.

State of Design ADs can be obtained directly from the EASA website at:
<http://ad.easa.europa.eu/>

Links to other NAA websites are available on the CAA website at:
[Links to state of design airworthiness directives | aviation.govt.nz](#)
 3. The ADs in this schedule are aligned with those applicable ADs issued by Direction générale de l'Aviation civile (DGAC) and European Union Aviation Safety Agency (EASA).
 4. Upgraded Eurocopter/Aerospatiale AS 350 series helicopters require that ADs applicable to the original model be reviewed for applicability and complied with accordingly.
 5. Modified Eurocopter/Aerospatiale AS 350 series helicopters fitted with AS 355 aircraft parts require that ADs applicable to the AS 355 series be reviewed for applicability and complied with accordingly.
 6. The date above indicates the amendment date of this schedule.
 7. New or amended ADs are shown with an asterisk *
-

Contents

DCA/AS350/1	Tail Rotor Swivel Joint - Inspection	6
DCA/AS350/2	Tail Rotor Pitch Control Links - Inspection	6
DCA/AS350/3	Tail Rotor Gear Box, Attachment Screws - Replacement	6
DCA/AS350/4	Flying Controls - Modification	6
DCA/AS350/5	Main Rotor Dampers - Inspection.....	6
DCA/AS350/6	Baggage Door - Inspection	6
DCA/AS350/7	Tail Rotor Gear Box - Modification	7
DCA/AS350/8	Tail Rotor Hub - Modification.....	7
DCA/AS350/9A	Engine Condition Monitoring System - Modification	7
DCA/AS350/10	Main Gear Box Temperature Probe - Inspection and Modification.....	7
DCA/AS350/11A	Main Rotor Head Assembly - Inspection	7
DCA/AS350/12	Main Rotor Drive - Inspection.....	8
DCA/AS350/13	Main Gear Box Oil - Inspection	8
DCA/AS350/14	Cargo-Swing Installation - Modification	8
DCA/AS350/15	Engine To Main Gear Box Coupling - Inspection	8
DCA/AS350/16	Tail Rotor Installation - Inspection.....	8

DCA/AS350/17A	Tail Rotor Blade Assembly - Retirement	8
DCA/AS350/18B	Fin Installation - Inspection and Modification	9
DCA/AS350/19C	Cancelled – DCA/AS350/31A refers	9
DCA/AS350/20	Tail Rotor Blades - Inspection	9
DCA/AS350/21C	Cancelled – DCA/AS350/50 now refers	9
DCA/AS350/22A	Main Gear Box, Bevel Ring Gear Assembly - Inspection	9
DCA/AS350/23F	Cancelled – EASA AD 2024-0133 refers	10
DCA/AS350/24	Main Gear Box Oil Filter - Inspection	10
DCA/AS350/25B	Main Rotor Shaft - Inspection.....	10
DCA/AS350/26	Emergency Flotation System - Modification	10
DCA/AS350/27	Fuel Filter Drain - Modification	11
DCA/AS350/28	Oil and Fuel Filters - Inspection	11
DCA/AS350/29	Raised Skid Landing Gear - Modification	11
DCA/AS350/30	Main Rotor Head - Life Limitation and Inspection	11
DCA/AS350/31A	Fuel Filter - Inspection and Modification.....	12
DCA/AS350/32	Fuel Filter - Inspection.....	12
DCA/AS350/33E	Main Rotor Head, Main Gear Box and Landing Gear – Inspection	12
DCA/AS350/34	Sliding Doors - Modification	13
DCA/AS350/35	Main and Tail Rotor Servo Controls - Inspection.....	13
DCA/AS350/36B	Main Rotor, Rotating Swash Plate - Inspection.....	13
DCA/AS350/37	Cancelled - CAR 91.603(b) refers	13
DCA/AS350/38	Tail Rotor Pitch Control Lever Expansion Pin - Inspection.....	13
DCA/AS350/39	Emergency Location Transmitter (ELT) Antenna - Modification	14
DCA/AS350/40	Hydraulic Reservoir - Modification.....	14
DCA/AS350/41A	Pitch Change Lever Bushes - Inspection	14
DCA/AS350/42	Engine Fire Detection System - Modification	14
DCA/AS350/43	Main Rotor Mast Assembly - Inspection.....	14
DCA/AS350/44A	Sliding Windows - Inspection and Modification	15
DCA/AS350/45	MGB Oil Pressure Switch - Removal	15
DCA/AS350/46	Cyclic Pitch Change Control Rod - Inspection	15
DCA/AS350/47	Main Rotor Shaft Oil Jet - Inspection.....	15
DCA/AS350/48	MGB Suspension Bi-directional Cross Beam - Inspection	16
DCA/AS350/49	Tail Boom Attachment Screws - Replacement.....	16
DCA/AS350/50	Cancelled – EASA AD 2015-0195 refers	17
DCA/AS350/51	Single Pole Circuit Breakers – Inspection and Removal	17
DCA/AS350/52B	Tail Rotor Hub Pitch Change Plate Bearings - Inspection.....	17
DCA/AS350/53	NR Indicator Lighting - Modification	18
DCA/AS350/54A	Tail Rotor Pitch Change Rotating Plates – Inspection and Modification.....	18
DCA/AS350/55	Engine Oil Tank Breather Pipe - Fireproofing	19
DCA/AS350/56	Ferry Fuel Tanks - Electrical Bonding	19
DCA/AS350/57B	Tail Rotor Drive Shaft Forward Fairing - Inspection	19
DCA/AS350/58	Tail Rotor Hub Pitch Change Plate Bearings - Replacement.....	21
DCA/AS350/59	Cancelled – DCA/AS350/108 refers.....	21
DCA/AS350/60	Engine Indication System – Resistor Installation	21
DCA/AS350/61A	Cancelled – DGAC AD 2001-557-086R3 refers.....	21
DCA/AS350/62	Cancelled – DCA/AS350/74 refers.....	21
DCA/AS350/63B	Tail Servo Control Eye End Fitting – Inspection and Rework.....	22
DCA/AS350/64	Engine Control Switch – Inspection.....	22
DCA/AS350/65	Hydraulic Cut-Off Control - Modification.....	22
DCA/AS350/66	Cancelled - DCA/AS350/94 refers.....	23
DCA/AS350/67	HSI - Inspection	23
DCA/AS350/68	Hawker Pacific TRW-SAMM Main Servocontrols - Replacement	23
DCA/AS350/69	Eurocopter Canada Collective Lock - Replacement.....	23
DCA/AS350/70	Cancelled – EASA AD 2019-0228 refers	23

DCA/AS350/71	Cyclic Friction Cup - Inspection.....	24
DCA/AS350/72	Dynamic Components – Life Correction.....	24
DCA/AS350/73A	Battery Lug - Inspection	24
DCA/AS350/74	TRW-SAMM Servo Controls - Replacement.....	25
DCA/AS350/75A	Flight Control Stops – Inspection and Modification	26
DCA/AS350/76	Collective Lever Lock – Inspection.....	26
DCA/AS350/77	Fuel Bleed Lever - Modification.....	26
DCA/AS350/78	Rear Fuselage - Inspection.....	26
DCA/AS350/79	Tail Rotor Control Cable - Replacement	27
DCA/AS350/80A	Cancelled – DCA/AS350/112 refers.....	27
DCA/AS350/81	Hydraulic System Cut-off- Modification	27
DCA/AS350/82	Cancelled - DCA/AS350/98 refers.....	27
DCA/AS350/83	Tail Rotor Blade Trailing Edge Tab – Inspection and Modification.....	28
DCA/AS350/84B	Cancelled - DCA/AS350/99 refers.....	28
DCA/AS350/85	Cancelled – DCA/AS350/86 refers.....	28
DCA/AS350/86	Cancelled - DCA/AS350/97 refers.....	28
DCA/AS350/87	Breeze Eastern 450-lb Electric Hoist - Inspection	28
DCA/AS350/88	Cancelled – DCA/AS350/91 refers.....	29
DCA/AS350/89	Main Servo Controls – Inspection and Replacement	29
DCA/AS350/90	Cancelled – DCA/AS350/109 refers.....	30
DCA/AS350/91	Cancelled – DCA/AS350/109 refers.....	30
DCA/AS350/92	Cancelled – DCA/AS350/126 refers.....	30
DCA/AS350/93	Twist Grip Solenoid – Inspection, Operation and Replacement.....	30
DCA/AS350/94	Cancelled – DCA/AS350/103 refers.....	30
DCA/AS350/95	Cancelled - DCA/EMY/27 refers	30
DCA/AS350/96A	Tail Rotor Servo Control – Inspection and Rework	31
DCA/AS350/97B	Cancelled – DCA/AS350/106 refers.....	31
DCA/AS350/98	Sliding Door Rollers and Rails – Inspection and Modification	31
DCA/AS350/99	RH Cabin Vibration Damper and Blade Assy – Inspection and Modification.....	32
DCA/AS350/100	Starter Generator – Load Limitation.....	32
DCA/AS350/101	Yaw Control Load Compensator Lever – Inspection.....	33
DCA/AS350/102	Main & Tail Rotor Servo Controls – Inspection and Rework	33
DCA/AS350/103C	Tail Rotor Blade Skin – Inspection and Repair.....	34
DCA/AS350/104	Cabin Floor Cross Member – Inspection and Rework.....	34
DCA/AS350/105	Main & Tail Rotor Servo Controls – Inspection and Replacement	35
DCA/AS350/106	Sliding Door Rear Fitting and Support Shaft – Inspection and Replacement.....	36
DCA/AS350/107	Collective Lever Recess - Modification	36
DCA/AS350/108	Rear Bench Seat Cushions – Removal or Modification.....	37
DCA/AS350/109	Cancelled – DCA/AS350/114 refers.....	37
DCA/AS350/110	Aerazur Emergency Flotation Gear - Inspection and Replacement	37
DCA/AS350/111A	Cancelled – DCA/AS350/115 refers.....	38
DCA/AS350/112	Emergency Flotation Gear – Inspection, Placard and Replacement.....	38
DCA/AS350/113	Cancelled – DCA/AS350/116 refers.....	39
DCA/AS350/114	Fin Attach Fittings – Inspection, Modification & Replacement.....	39
DCA/AS350/115B	Collective Lever Lock – Inspection and Rework.....	40
DCA/AS350/116	Starter Generator Damping Assembly – Adjustment and Marking.....	41
DCA/AS350/117	Cancelled – EASA AD 2013-0061 refers	41
DCA/AS350/118	Cancelled – EASA AD 2010-0006 refers	41
DCA/AS350/119	Cancelled – DCA/AS350/120 refers.....	42
DCA/AS350/120	Tail Gearbox Control Lever – Inspection, Rework and Replacement.....	42
DCA/AS350/121	Hydraulic Servo Hoses – Inspection and Rework	43
DCA/AS350/122	EASA AD 2011-0072 Cancelled by EASA on 4 March 2022	43
DCA/AS350/123	Tail Gearbox Casing Assembly – Inspection and Replacement.....	43
DCA/AS350/124	Cancelled – EASA AD 2011-0164R1 refers.....	44

DCA/AS350/125	Cancelled – EASA AD 2013-0281 refers	44
DCA/AS350/126	Cancelled – EASA AD 2012-0252 refers	44
DCA/AS350/127	Fire Detection System – Modification.....	44
<p>The State of Design ADs listed below are available directly from the National Airworthiness Authority (NAA) websites. Links to NAA websites are available on the CAA website at Links to state of design airworthiness directives aviation.govt.nz If additional NZ ADs need to be issued when an unsafe condition is found to exist in an aircraft or aeronautical product in NZ, they will be added to the list below.</p>		
2012-0205	Sliding Door Lower Ball-joint – Modification	45
2012-0207-E	Cancelled – EASA AD 2012-0217-E refers.....	45
2012-0217-E	Cancelled – EASA AD 2013-0029 refers	45
2012-0252	Cancelled – EASA AD 2017-0035 refers	45
2012-0257-E	Cancelled by EASA AD 2012-0257-CN – Purpose fulfilled	45
2013-0029	Tail Rotor Laminated Half Bearings – Inspection	45
2013-0044-E	Cancelled – EASA AD 2013-0284-E refers.....	45
2013-0061	Cancelled – EASA AD 2013-0191-E refers.....	45
2013-0088	Cancelled – EASA AD 2015-0132 refers	45
2013-0095-E	Main/Tail Rotor Servo-Control Bearings – Inspection and Replacement	45
2013-0133-CN	Cancelled – Purpose fulfilled.....	45
2013-0191-E	Cancelled – EASA AD 2017-0052 refers	46
2010-0006	Cancelled by EASA on 3 September 2021	46
2013-0281R1	Position Strobe Light – Inspection.....	46
2013-0284R1	Cancelled – EASA AD 2014-0233 refers	46
2013-0287	Cancelled – EASA AD 2021-0195 Refers.....	46
2014-0076R3	Cancelled – EASA AD 2022-0051 refers	46
2014-0132R1	Rotating Star Swashplate – Inspection	46
2014-0233	Hydraulic Pump Bearing - Inspection.....	46
Transport Canada AD CF-2015-10 STC SR00825NY-D	Hydraulic Test Switch Replacement.....	46
2015-0094	Cancelled by EASA on 3 September 2021	46
DGAC AD 1991-165-058R1	Electric Hoist Bonding – Inspection.....	47
2015-0132	Cancelled – EASA AD 2021-0194 Refers.....	47
2015-0178	Normal Procedures – AFM Amendment	47
2015-0195	Tail Rotor Drive Shaft Bearings – Inspection	47
DCA/AS350/128C	Forward Two-place Seat - Operating Limitations	47
2016-0020	Main Gearbox Casings – Inspection	50
2016-0021	Main Gearbox Bottom Casing – Inspection.....	50
2016-0220	Dual Hydraulic System – Inspection.....	50
2016-0260	Main Rotor NR Indicator – Inspection	50
2017-0020R1	Tail Rotor Pitch Rod – Inspection.....	50
2011-0164R3	Tail Rotor Control Stop Screws – Inspection.....	50
2017-0032	Cancelled by EASA on 11 August 2021.....	51
2017-0035	Twist Grip Assembly – Inspection	51
2017-0052	Cancelled – EASA AD 2017-0059 refers	51
2017-0059	Cancelled – EASA AD 2023-0133 refers	51
2017-0089R1	Main Rotor Mast Upper Bearing - Inspection	51
2017-0109 (Correction)	Starter Generator and Brushes - Inspection.....	51
2017-0114	Cancelled - EASA AD 2020-0186 refers	51
2017-0143	Direct Current (Optional) Second Battery – Replacement.....	51
Transport Canada AD CF-2017-37	Restriction of Directional Control Pedal Movement.....	51
DCA/AS350/129A	Cargo Swing Modification OAL114 – Inspection	52
2018-0152	Cancelled – EASA AD 2022-0128 refers	52
2018-0206	Mast Upper Bearing Sealant Bead/Inner Race Retaining Rings - Inspection.....	52
FAA AD 2018-18-12	Cancelled – FAA AD 2019-16-16 refers.....	52
FAA AD 2018-25-17	Air Comm Corp Air Conditioning System – Inspection.....	52
2018-0287	Cancelled – EASA AD 2019-0060 refers	52
DCA/AS350/130	HETS STC 11/21E/34 – Removal from Service.....	53

Transport Canada CF-2019-01	Helicopter External Transport System (HETS) STC SH98-35.....	53
2019-0060	Tail Rotor Gearbox Actuating Rod – Inspection	53
DGAC AD 2001-557-086R3	Starflex Star – Inspection	53
2019-0184	Main Rotor Servo Actuators – Inspection.....	54
FAA AD 2019-16-16	Inlet Barrier Filter – Inspection	54
2019-0225-E	MGB Drive Shaft / Engine Coupling – Inspection.....	54
2019-0228	Electric Hoist Installation – Inspection.....	54
2019-0280	Spherical Bearing – Inspection	54
FAA AD 2020-02-23	Emergency Float System STC SR00470LA – Inspection	54
DCA/AS350/131	Dual Front Seat Modification MB 25.20.05 - Inspection	54
2020-0064	Emergency Flotation System – Inspection	55
2020-0175	Cancelled by EASA on 13 September 2021	55
2020-0186	Cancelled – EASA AD 2021-0099 refers	55
2020-0217-E	Cancelled – EASA AD 2021-0023 refers	55
2020-0224R1	Tail Rotor Blades – Inspection	55
2021-0023	Cyclic Stick Grip UP / Down Hoist Control Switch – Modification.....	55
2021-0048	Cancelled – EASA AD 2023-0064 refers	56
2021-0099	Cancelled – EASA AD 2023-0075 refers	56
2021-0123-E	Tail Rotor Load Compensator – Inspection.....	56
2021-0168	Cancelled – EASA AD 2024-0018 refers	56
2021-0194R1	Cancelled – EASA AD 2024-0133 refers	56
2021-0195	Engine Digital ECU Emergency Procedure – AFM Amendment.....	56
2021-0282R1 (Correction)	Tail Rotor Head Pitch Change Unit Bearing Spacer - Inspection.....	56
2022-0051	(Correction) Rear Structure Junction Frame Reinforcement Angles - Inspection.....	56
2022-0077-E	Flight Control Flexball Cables - Replacement.....	56
2022-0128	Main Gearbox Bracket Bolts - Inspection	56
2022-0246	Main Rotor Blades - Inspection	56
2023-0044	Main Gearbox Planet Gear - Inspection	57
2023-0064	Main Rotor Pitch Rod Upper Links - Inspection	57
2023-0075	Cancelled – EASA AD 2023-0089 refers	57
2023-0089	Cancelled – EASA AD 2024-0139 refers	57
2023-0107	(Correction) Cargo Swing Frame - Inspection.....	57
2023-0127	Main Gearbox Engine Coupling - Inspection.....	57
2023-0131	Sliding Doors - Inspection	57
2023-0133	Cancelled – EASA AD 2023-0187 refers	57
* 2023-0187R1	Microswitches - Inspection.....	57
2024-0018	Indicating / Recording Systems Control Unit – Inspection.....	58
2024-0133	Airworthiness Limitations Section - Amendment.....	58
2024-0139	Vertical Fin - Inspection.....	58
2025-0025	Emergency Release Control of Cargo Swing Installation – Inspection.....	58
2025-0036	Cargo Hook Assembly – Inspection.....	58

DCA/AS350/1 Tail Rotor Swivel Joint - Inspection

Applicability: All Model AS350 not incorporating mods. AMS 350A.07.6513 and AMS 350A.07.8515.

Requirement: Inspect per Aerospatiale SB 05.01.
(DGAC AD 1978-193-001 refers)

Compliance: At intervals not exceeding 50 hours TIS.

Effective Date: 17 August 1979

DCA/AS350/2 Tail Rotor Pitch Control Links - Inspection

Applicability: All Model AS350 not incorporating mods. AMS 350A.07.6510 or AMS 350A.07.6512 and AMS 350A.07.5524.

Requirement: Inspect per Aerospatiale SB 05.02 paras 1C.1(A) and 1C.1(B).
(DGAC AD 1978-193-001 refers)

Compliance: Para 1C.1(A) - Prior to every flight.
Para 1C.1(B) - At intervals not exceeding 10 hours TIS.

Effective Date: 17 August 1979

DCA/AS350/3 Tail Rotor Gear Box, Attachment Screws - Replacement

Applicability: All Model AS350 not incorporating mod. AMS 350A.07.8517.

Requirement: Embody replacement screws per Aerospatiale SB 65.07.
(DGAC AD F-1979-012-004 refers)

Compliance: Within the next 50 hours TIS

Effective Date: 17 August 1979

DCA/AS350/4 Flying Controls - Modification

Applicability: All Model AS350 not incorporating mod. AMS 350A.07.0452.

Requirement: Embody control rod P/N 704A.34.113 per Aerospatiale SB 67.01.
(DGAC AD 1979-013-005 refers)

Compliance: Within next 100 hours TIS unless already accomplished.

Effective Date: 17 August 1979

DCA/AS350/5 Main Rotor Dampers - Inspection

Applicability: All Model AS350 not incorporating mod. AMS 350.07.6063.

Requirement: Inspect per Aerospatiale SB 05.03.
(DGAC AD 1979-104-006 refers)

Compliance: At intervals not exceeding 25 hours TIS.

Effective Date: 17 August 1979

DCA/AS350/6 Baggage Door - Inspection

Applicability: All Model AS350.

Requirement: Inspect L.H. baggage door for correct latching per Aerospatiale SB 52.04.
Deficient installations shall be corrected before further flight.
(DGAC AD 1979-133-007 refers)

Compliance: By 8 August 1979

Effective Date: 31 July 1979

DCA/AS350/7 Tail Rotor Gear Box - Modification**Applicability:** All Model AS350 not incorporating mod. AMS 07.8519.**Requirement:** Modify per Aerospatiale SB 65.08.
(DGAC AD 1979-174-009 refers)**Compliance:** By 31 October 1979**Effective Date:** 28 September 1979**DCA/AS350/8 Tail Rotor Hub - Modification****Applicability:** All Model AS350**Requirement:** Modify per Aerospatiale SB 65.13.
(DGAC AD 1979-217-011 refers)**Compliance:** By 31 January 1980**Effective Date:** 21 December 1979**DCA/AS350/9A Engine Condition Monitoring System - Modification****Applicability:** All Model AS350B not incorporating mods. AMS 07.0615 and 07.0804.**Requirement:** Embody modifications AMS 07.0615 and 07.0804 per Aerospatiale SB 77.02 issue 2.
(DGAC AD 1980-165-014 refers)**Compliance:** Mod. 07.0615 - By 31 March 1980

Mod. 07.0804 - By 31 March 1981

Effective Date: DCA/AS350/9 - 22 February 1980
DCA/AS350/9A - 21 November 1981**DCA/AS350/10 Main Gear Box Temperature Probe - Inspection and Modification****Applicability:** All Model AS350 not incorporating mod. AMS 350A.07.0733.**Requirement:** Inspect and modify per Aerospatiale SB 65.18. Probe installations found defective shall be modified before further flight.
(DGAC AD F-1980-104-013 refers)**Compliance:** Inspection - Prior to next flight unless already accomplished.

Modification - not later than next 300 hour inspection.

Effective Date: 6 June 1980**DCA/AS350/11A Main Rotor Head Assembly - Inspection****Applicability:** All Model AS350**Requirement:** Check starflex attachment bolt torque, inspect and/or renew bolts as necessary, per Aerospatiale SB 05.04 Rev.1.
(DGAC AD 1980-184-015R1 refers).**Compliance:** At 600 hours TTIS and thereafter at intervals not exceeding 400 hours TIS.

Aircraft with 590 hours or more TIS shall be initially inspected within next 10 hours TIS unless already accomplished

Effective Date: DCA/AS350/11 - 21 November 1980
DCA/AS350/11A - 18 March 1988

DCA/AS350/12 Main Rotor Drive - Inspection

- Applicability:** All Model AS350 with bevel gear module P/N 350A32.0300.00, .01 or .02.
- Requirement:** Inspect per Aerospatiale telex service bulletin 05.05. Modules with indications of excessive wear must be removed from service before further flight.
- Compliance:** At 600 hours TTIS and thereafter at intervals not exceeding 150 hours TIS. Modules with 580 hours or more TIS, shall be initially inspected within next 20 hours TIS unless already accomplished.
- Effective Date:** 9 January 1981.

DCA/AS350/13 Main Gear Box Oil - Inspection

- Applicability:** All Model AS350 with spiro conical modules not incorporating mods. 07.7027 or 07.7042.
- Requirement:** Accomplish spectrometric oil analysis per Aerospatiale telex SB 05.06. Modules with indication of excessive wear must be removed from service before further flight. (DGAC AD F-1981-094-018 refers)
- Compliance:** At 300 hours TTIS and thereafter at intervals not exceeding 300 hours TIS.
- Effective Date:** 3 April 1981

DCA/AS350/14 Cargo-Swing Installation - Modification

- Applicability:** All Model AS350 with cargo-swing installation.
- Requirement:** Modify per Aerospatiale SB 25.19. (DGAC AD 1981-067-016 refers).
- Compliance:** Prior to next use of cargo-swing installation.
- Effective Date:** 12 June 1981.

DCA/AS350/15 Engine To Main Gear Box Coupling - Inspection

- Applicability:** All Model AS350.
- Requirement:** Inspect attachment bolts per Aerospatiale SB 01.06 and renew as necessary before further flight. (DGAC AD 1981-084-017 refers)
- Compliance:** At next 300 hour inspection.
- Effective Date:** 12 June 1981.

DCA/AS350/16 Tail Rotor Installation - Inspection

- Applicability:** All Model AS350
- Requirement:** Accomplish dye penetrant and visual inspections per Aerospatiale telex SB 01.07A.
- Compliance:** Dye penetrant inspection - within next 10 hours TIS.
Visual inspection - following last flight on each day aircraft is operated.
- Effective Date:** 13 June 1981

DCA/AS350/17A Tail Rotor Blade Assembly - Retirement

- Applicability:** All Model AS350
- Requirement:** Retire tail rotor pitch change horn assemblies P/N 350A12.1368.01 and 350A12.1368.02 from service. (DGAC AD 1981-184-020 refers)
- Compliance:** P/N 350A12.1368.01 - at 450 hours TTIS.
P/N 350A12.1368.02 - at 1250 hours TTIS.
- Effective Date:** DCA/AS350/17 - 6 July 1981
DCA/AS350/17A - 11 December 1981

DCA/AS350/18B Fin Installation - Inspection and Modification

- Applicability:** All Model AS350 not incorporating mod. 07.1047.
- Requirement:** 1. Inspect per Aerospatiale telex SB 05.07 and SB 05.09.
2. Modify per Aerospatiale SB 55.02 Rev.1.
(DGAC AD F-1982-098-026 refers)
- Compliance:** 1. Inspections - At intervals not exceeding 10 hours TIS until modified per Aerospatiale SB's 55.02 Rev.1 and 55.03 respectively.
2. Modification - within next 100 hours TIS.
- Effective Date:** DCA/AS350/18A - 12 February 1982
DCA/AS350/18B - 27 August 1982

DCA/AS350/19C Cancelled – DCA/AS350/31A refers

Effective Date: 30 August 2007

DCA/AS350/20 Tail Rotor Blades - Inspection

- Applicability:** All Model AS350 with tail rotor blades, P/N 350.12.0020 all dash numbers, 350.12.0030.00 all dash numbers and 350A.08.1011.00.
- Requirement:** Inspect tail rotor blades for bonding separation of leading edge stainless steel protection strips per Aerospatiale work card AS350.65.20.601.
(DGAC AD 1982-024-024 refers).
- Compliance:** 1. Blades with 100 hours or less TTIS or since overhaul - at intervals not exceeding 10 hours TIS until accumulation of 100 hours TIS and thereafter per Aerospatiale M.S.R. AS350 CH5.24 P.2 latest issue.
2. Blades which have exceeded 100 hours TTIS or since overhaul - within next 10 hours TIS, and thereafter per Aerospatiale M.S.R. AS350 CH5.24 P.2 latest issue.
- Effective Date:** 30 April 1982

DCA/AS350/21C Cancelled – DCA/AS350/50 now refers

Effective Date: 28 August 1998

DCA/AS350/22A Main Gear Box, Bevel Ring Gear Assembly - Inspection

- Applicability:** All Model AS350 with bevel reduction gear assemblies P/N 350A32.0300.00.01 and .02 not incorporating mods. AMS 07.7082, AMS 07.7083 or AMS 07.7098.
- Requirement:** Visually inspect per Aerospatiale SB 05.10 para 1C(1) and check screw torques per para 1C(2).
Correct defective screw installations before further flight.
(DGAC AD 1985-068-038 refers).
- Compliance:** Visual inspection - at intervals not exceeding 50 hours TIS until screw torque check accomplished and thereafter at intervals not exceeding 300 hours TIS.
Torque check - Within next 300 hours TIS unless already accomplished.
- Effective Date:** DCA/AS350/22 - 11 February 1983
DCA/AS350/22A - 2 August 1985

DCA/AS350/23F Cancelled – EASA AD 2024-0133 refers

Effective Date: 25 July 2024

DCA/AS350/24 Main Gear Box Oil Filter - Inspection

Applicability: All model AS350 fitted with 'TEDECO' magnetic plug P/N B4439 per mod 350A.07.0720 (AS 350 SB 65-20).

Requirement: Inspect oil filter per Aerospatiale SB 05.12. (DGAC AD 82-175-29 refers).

Compliance: At intervals not exceeding 100 hours TIS.

Effective Date: 11 February 1983.

DCA/AS350/25B Main Rotor Shaft - Inspection

Applicability: All Model AS350 with rotor shaft P/N 350A37.1076.00 to .06.

Requirement: Inspect per Aerospatiale SB 05.13 Rev.2. Renew defective part before further flight. (DGAC AD 1983-173-036 refers)

Compliance:

1. At 300 hours TTIS or within next 50 hours TIS, whichever is the later and thereafter at intervals not exceeding 300 hours TIS.
2. Before further flight following severe rotor tracking abnormalities.

Effective Date: DCA/AS350/25A - 2 March 1984
DCA/AS350/25B - 2 May 1986

DCA/AS350/26 Emergency Flotation System - Modification

Applicability: All Model AS350B, C and D-1 with air cruiser flotation system installed per STC SH4032SW or SH2825SW.

Requirement: Modify flotation system per FAA AD 83-11-01 R1. (FAA AD 83-11-01R1 refers)

Compliance: Prior to next overwater flight, unless already accomplished.

Effective Date: 1 March 1985

DCA/AS350/27 Fuel Filter Drain - Modification

- Applicability:** Model AS350B and AS350D S/Ns 1 through 1808, 1813 through 1826 except 1818 and 1822
- Requirement:** Modify fuel filter drain in accordance with SB 28.06.
(DGAC 1985-066-039 refers)
- Compliance:** Before 1 September 1985
- Effective Date:** 2 August 1985.

DCA/AS350/28 Oil and Fuel Filters - Inspection

- Applicability:** All Model AS350
- Requirement:** 1. Inspect main gear box filter and fuel filter cartridges for correct installation per Aerospatiale Telex SB No. 01.14 including amendment 01.14A.
2. When installing replacement 'LEBOZEC' and 'GAUTHIER' filters ensure that:
Fuel filter P/N 432 B12.30 filter cartridge is marked 'FUEL'
Oil filter P/N 434 B12.11 filter cartridge is marked 'OIL'.
(DGAC AD 1985-135-042 refers)
- Compliance:** 1. Inspection - Within next 5 hours TIS unless already accomplished
2. Filter check - Prior to installation
- Effective Date:** 28 February 1986

DCA/AS350/29 Raised Skid Landing Gear - Modification

- Applicability:** All Model AS350 with raised skid landing gear and flotation gear installation not incorporating mod. AMS 350A.07.1755
- Requirement:** To prevent possible interference between landing gear steps and flotation bags when inflated, remove steps per Aerospatiale Telex SB 32.06A
(DGAC AD 1986-030-043 refers)
- Compliance:** By 31 May 1986, or prior to flotation gear installation.
- Effective Date:** 2 May 1986

DCA/AS350/30 Main Rotor Head - Life Limitation and Inspection

- Applicability:** All Model AS350B and AS350D with roving sleeve upper and lower beams P/N 350A31.1830.00 and .01; 350A31.1831.00, .04, .05, .06 and .07
- Requirement:** 1. Remove affected beams from service per Aerospatiale telex SB 01.16 para BB at 4000 hours TTIS. Beams with 3900 hours or more TIS must be removed within next 100 hours TIS.
2. In the event of sudden or repeated occurrence or severe rotor tracking problems inspect per telex SB 01.16 para CC before further flight. If sleeve bush separation found remove beam from service before further flight.
(DGAC AD 1986-057-044 refers)
- Effective Date:** 1 August 1986

DCA/AS350/31A Fuel Filter - Inspection and Modification

- Applicability:** All Model AS350B and AS350D without modification 07.1671 embodied.
- Note:** This AD is no longer applicable once modification 07.1671 is embodied and supersedes DCA/AS350/19C.
- Requirement:** To prevent leaks at the fuel system filter and drain valve, accomplish the following:
1. Pull the drain valve to ensure it is correctly seated. Switch the fuel pump on and confirm that the drain valve does not leak. If any leak is detected repair as required, before further flight.
 2. Embody modification 07.1671 per the instructions in Aerospatiale SB 28.07. (DGAC ADs 1986-077-046(B)R2 and 1986-070-045(B) refers)
- Compliance:**
1. Check the drain valve whenever the filter drain is operated until requirement 2 of this AD is accomplished.
 2. By 30 November 2007, unless already accomplished.
- Effective Date:** DCA/AS250/31 - 1 August 1986
DCA/AS350/31A - 30 August 2007

DCA/AS350/32 Fuel Filter - Inspection

- Applicability:** All Model AS350 with LEBOZEC and GAUTHIER fuel filter P/N 432B12.3, .3C or P/N 350A52-1070.00 (post mod. 07.1671)
- Requirement:** To prevent leaks at fuel system filter, check that filter bowl is correctly tightened per instruction given on M.E.T. work card 28.00.00.302 page 3 rev.5A dated 86.21 and subsequent revisions.
(DGAC AD 1986-097-047 and Aerospatiale telex SB 28.08 refer)
- Compliance:** Within 50 hours TIS and thereafter whenever filter bowl is disturbed for any other reason.
- Effective Date:** 1 August 1986

DCA/AS350/33E Main Rotor Head, Main Gear Box and Landing Gear – Inspection

- Applicability:** All model AS350 B, B1, C, D and D1 aircraft.
- Note:** The compliance time for requirement 1 extended to 600 hours TIS with no change to the AD requirement. Aerospatiale SB 01.17A can be obtained from the Eurocopter T.I.P.I. web site under AS 350 ASB 01.00.17
- Requirement:** To prevent failure of main rotor (M/R) star arms and main gear box (MGB) suspension bars, accomplish the following:
1. Inspect the M/R head components, the MGB suspension bars (struts) and landing gear per paragraph CC3, subparagraph CCA, CCB and CCC in Aerospatiale SB 01.17A or later approved revisions. Rework or renew defective parts before further flight.
 2. Inspect the M/R head components and MGB suspension bars per paragraph CC3 subparagraphs CCA and CCB in SB 01.17A. Rework or renew defective parts before further flight.
(BV AD 1986-125-48R1 refers)
- Compliance:**
1. At intervals not to exceed 600 hours TIS. Prior to further flight following a hard landing which causes abnormal self sustained dynamic vibrations (ground resonance type).
 2. Prior to further flight following a hard landing or exposure to high winds without the M/R blades secured.
- Effective Date:** DCA/AS350/33C - 16 January 1998
DCA/AS350/33D - 25 September 1998
DCA/AS350/33E - 30 September 2010

DCA/AS350/34 Sliding Doors - Modification

- Applicability:** All Model AS350 with LH and/or RH sliding doors.
- Requirement:** To preclude the possibility of door loss in flight, modify per Aerospatiale SB 52.18. (DGAC AD 1987-088-049 refers)
- Compliance:** By 31 May 1988
- Effective Date:** 18 March 1988

DCA/AS350/35 Main and Tail Rotor Servo Controls - Inspection

- Applicability:** All Model AS350 with Dunlop main and tail rotor servo controls P/N AC64182, AC67030, AC67244, AC66442, AC67034, AC67246, AC66436, AC67032.
- Requirement:** To preclude possible failure of servo control assembly bolts, inspect per Aerospatiale SB 01.21 and renew bolts as prescribed. (DGAC AD 1988-184-052 refers)
- Compliance:** Within next 50 hours TIS or by 31 May 1989 whichever is the sooner.
- Effective Date:** 10 March 1989

DCA/AS350/36B Main Rotor, Rotating Swash Plate - Inspection

- Applicability:** All Model AS350B, B1, B2 and D with swash plates fitted with bearings P/Ns VH 36132 (704A33.651.051), Y 51BB 10843 SIM 73 (704A33.651.080), INA 36132 A (704A33.651.126).
- Requirement:** To prevent seizing of the swash plate bearing, inspect and lubricate per Aerospatiale SB 62.12R2. Renew defective parts before further flight. (DGAC AD 1989-155-054R4 refers)
- Compliance:**
 1. Within next 10 hours TIS (T.I.S.), unless already accomplished, and thereafter relubricate per SB 62.12R2 para 1.C-i at intervals not exceeding 100 hours T.I.S.
 2. Check per SB 62.12R2 para 1.C-g following last flight on each day aircraft is operated.
- Effective Date:** DCA/AS350/36A - 2 March 1990
DCA/AS350/36B - 29 November 1991

DCA/AS350/37 Cancelled - CAR 91.603(b) refers

- Effective Date:** 27 August 2009

DCA/AS350/38 Tail Rotor Pitch Control Lever Expansion Pin - Inspection

- Applicability:** All Model AS350B, B1, B2 and D.
- Requirement:** To prevent failure of the tail rotor pitch control lever hinge yoke lugs due to incorrect assembly, accomplish the following:-
 1. Inspect the pitch control rod support yoke for cracks per para B of Aerospatiale Telex SB NR 01-33. If a crack is found replace the TGB per the SB before further flight.
 2. Inspect for correct installation of the expansion pin per para C of Aerospatiale Telex SB NR 01-33. Rectify if necessary as prescribed by the SB, before further flight. (DGAC AD 1991-137-059 refers)
- Compliance:**
 1. Within next 10 hours TIS (TIS) and thereafter at intervals not to exceed 10 hours TIS until part 2 is accomplished.
 2. Within next 50 hours TIS.
- Effective Date:** 4 July 1991

DCA/AS350/39 Emergency Location Transmitter (ELT) Antenna - Modification

- Applicability:** Model AS350 Series fitted with the JOLLIET ELT system
- Requirement:** To prevent loss of the ELT antenna in flight, modify per Eurocopter AS 350 SB 25.45. (DGAC AD 1992-144-061 refers)
- Compliance:** Within next 400 hours TIS or by 1 April 1993 whichever is the sooner.
- Effective Date:** 30 October 1992

DCA/AS350/40 Hydraulic Reservoir - Modification

- Applicability:** All Model AS350B, BA, B1, B2 and D fitted with hydraulic reservoir P/N 350A75-1030-00.
- Requirement:** To decontaminate the hydraulic system and prevent water entering the hydraulic reservoir, modify and flush the system per paragraph 2B1 or 2B2 of Eurocopter SB 01.36. (DGAC AD 1992-145-062 refers)
- Compliance:** For aircraft operating in temperatures of -10° C or less, within next 100 hours TIS or 3 months whichever is the sooner. For all other aircraft, within next 400 hours TIS.
- Effective Date:** 30 October 1992

DCA/AS350/41A Pitch Change Lever Bushes - Inspection

- Applicability:** All Model AS350B, BA, D, B1, B2 and L1 with pitch change lever P/N 350A 31.1877.02 not marked with an "X" and have a S/N less than 100,000.
- Requirement:** To prevent failure of the pitch change rod/lever coupling bolt and loss of pitch control, inspect per Eurocopter SB 62.21 R1. Renew defective parts per SB 62.21 R1. (DGAC AD 1992-179-064R1 refers)
- Compliance:** Within next 50 hours TIS.
- Effective Date:** DCA/AS350/41 - 27 November 1992
DCA/AS350/41A - 11 June 1993

DCA/AS350/42 Engine Fire Detection System - Modification

- Applicability:** Model AS350B1 and B2
- Requirement:** To ensure correct operation of the engine bay fire detection system, modify per Eurocopter SB 26-01. (DGAC AD 1992-159-063R2 refers)
- Compliance:** By 31 May 1993
- Effective Date:** 19 March 1993

DCA/AS350/43 Main Rotor Mast Assembly - Inspection

- Applicability:** Model AS350B, BA, B1, B2 and D fitted with main rotor mast assembly P/N 350A37.0004.02, 350A37.0004.03, 355A37.0005.01.
- Requirement:** As a result of an accident overseas involving an AS350B2, inspect per Eurocopter Telex Service 01-41, paragraphs DD (A) or (B) as appropriate and EE. (DGAC AD 1993-030-065 refers)
- Compliance:** 1. Whenever abnormal noises appear (metal rubbing) in flight or when the rotor is turning on the ground. Flights must be terminated as soon as practicable.
2. Within the next 5 hours TIS, for any main rotor mast shaft on which maintenance requiring the removal of the mast epicyclic reduction gear assembly has been performed during the last 100 hours TIS, unless the maintenance was performed by Eurocopter Marignane.
- Effective Date:** 27 March 1993

DCA/AS350/44A Sliding Windows - Inspection and Modification

Applicability: All Model AS350B, BA, B1, B2, D and L1 fitted with sliding window panes P/N: 704A41-512-003, -004, -005, -006, -010, -011, -025 and 355A25-2030-00.

Requirement: To prevent window separation in flight accomplish the following:-

1. Inspect per Eurocopter SB 05.25 R1. If cracks are found, or if a piece of the slide is unstuck and/or has been lost, replace the window per paragraph 1C3 of SB 05.25 R1 before further flight.
2. Modify (Repair) per paragraph 1C2 of SB 05.25 R1.
(DGAC AD 1993-090-067R1 refers)

Compliance:

1. Inspect within next 50 hours TIS and thereafter at intervals not to exceed 25 hours TIS, until modification per paragraph 1C2 of SB 05.25 R1. After modification, inspect at intervals not to exceed 100 hours TIS.
2. Modify within next 100 hours TIS.

Effective Date: DCA/AS350/44 - 3 September 1993
DCA/AS350/44A - 18 March 1994

DCA/AS350/45 MGB Oil Pressure Switch - Removal

Applicability: Model AS350B, BA, B1, B2, D and L1, fitted with MGB oil pressure switch P/N 704A37.721.082 (S 1130.021.082).

Requirement: Replace MGB oil pressure switch P/N 704A37.721.082 (S 1130.021.082) per Eurocopter Telex Service 01.43.
(DGAC AD 1994-087-068 refers)

Compliance: By 1 August 1994

Effective Date: 8 July 1994

DCA/AS350/46 Cyclic Pitch Change Control Rod - Inspection

Applicability: Model AS 350B, BA, B1, B2 and D, fitted with cyclic pitch change control rod P/N 704A34-113-279. This airworthiness directive does not apply to aircraft fitted with an autopilot.

Requirement: To ensure that cyclic pitch change control rods have been correctly safetied, inspect per Eurocopter SB 01-42. Replace any rods found not safetied per SB 01-42 before further flight.
(DGAC AD 1994-180-069 refers)

Compliance: Within next 100 hours TIS.

Effective Date: 23 December 1994

DCA/AS350/47 Main Rotor Shaft Oil Jet - Inspection

Applicability: Model AS350B, BA, B1, B2, D and L1, fitted with a "TIMKEN" main rotor shaft P/N 350A37-0003 (all dash numbers), that has logged less than 100 operating hours since new or overhaul.

Requirement: To ensure correct lubrication of the shaft bearing, accomplish the inspection per Eurocopter France AS 350 Telex Service No 01-44. Replace any assembly that does not comply with Telex Service No 01-44, before further flight.
(DGAC AD 1994-279-070R1 refers)

Compliance: Before further flight.

Effective Date: 9 March 1995

DCA/AS350/48 MGB Suspension Bi-directional Cross Beam - Inspection

- Applicability:** Model AS 350B, BA, B1, B2 and D fitted with a MGB suspension bi-directional cross beam P/N 350A38.1018 - (all dash numbers), installed on the complete cross beam assemblies P/N 350A38.0210 - (all dash numbers), not modified per MOD. 072720.
- Requirement:** To prevent failure of the suspension cross beam, accomplish the following:-
1. Cross beams that have logged at least 2000 hours TIS or 10,000 cycles:
 - 1.1 Within next 30 hours TIS and thereafter at intervals not to exceed 30 hours TIS or 150 cycles, whichever is the sooner, visually inspect the cross beam for cracks, per paragraph 2B(1) of Eurocopter France SB 05.00.28 and rectify defects if necessary as detailed.
 - 1.2 Each time the cross beam or the MGB is removed, irrespective of whether the removal was scheduled or not, comply with paragraph 2B(2) of SB 05.00.28.
 2. For cross beams that have logged more than 5000 hours TIS and which have not been checked during or since the last major inspection per paragraph 2B(2) of SB 05.00.28 accomplish the following:
 - 2.1 Within next 30 hours TIS and thereafter at intervals not to exceed 30 hours TIS or 150 cycles, whichever is the sooner, visually inspect both the upper faces of the cross beam for cracks, per paragraph 2B(1) of SB 05.00.28 and rectify any defects found as detailed.
 - 2.2 Within 550 hours TIS or 2750 cycles whichever is the later, comply with paragraph 2B(2) of SB 05.00.28.
- Note:** If there is no record of the number of the flying hours logged or of the number of cycles completed:
If the component has been installed on the aircraft since new, refer to the number of the flying hours and cycles logged by the airframe.
If the component has not been installed on the aircraft since new, comply with the instructions given in paragraph 2.1.
3. Before installing a cross beam as a replacement part that has already been installed on an aircraft, comply with the instructions given in paragraph 2B(2) of SB 05.00.28.
(DGAC AD 1996-156-071R1 refers)
- Compliance:** Compliance is required at the times specified within the requirement of this airworthiness directive.
- Effective Date:** 29 August 1997

DCA/AS350/49 Tail Boom Attachment Screws - Replacement

- Applicability:** Model AS 350B, BA, BB, B1, B2 and D fitted with tail boom attachment screws P/N 22201BC060008L (N5103337287). This AD does not apply to new or overhauled aircraft delivered after 15 May 1997 or to aircraft on which no tail boom attachment screws have been replaced since 1 July 1994.
- Requirement:** To prevent failure of the tail boom attachment screws, accomplish the following:-
- Check the marking on the heads of the 23 attachment screws which are located above the cargo compartment floor. Remove and scrap all screws which are marked with the letter "M" on their head above the designation "BC" per paragraph 2.B.1 of Eurocopter Alert Service Bulletin No. 01.00.46. Any affected screws held as spares must be scrapped per paragraph 2.B.2 of Eurocopter Alert Service Bulletin 01.00.46. (DGAC AD 1997-147-072R1 refers)
- Compliance:** Within next 100 hours TIS or by 29 September 1997, whichever is the sooner.
- Effective Date:** 29 August 1997

DCA/AS350/50 Cancelled – EASA AD 2015-0195 refers**Effective Date:** 7 October 2015**DCA/AS350/51 Single Pole Circuit Breakers – Inspection and Removal****Applicability:** AS 350 helicopters, versions: B, BA, BB, B1, B2, B3 and D equipped with single-pole CROUZET circuit breakers, P/Ns:

-5	amperes :	84 4000 032	Emergency flotation gear optional installation
-10	amperes :	84 4000 034	
-1	ampere :	84 4000 028	Other optional installations
-3	amperes :	84 4000 031	
-7.5	amperes :	84 4000 033	
-15	amperes :	84 4000 035	
-20	amperes :	84 4000 036	

(a) Delivered new between April 24, 1995, and August 31, 1996.

(b) Delivered new before April 24, 1995 or after August 31, 1996 if:

- Circuit breakers have been replaced on an optional equipment (emergency flotation gear or another optional equipment) since April 24, 1995.

- An optional equipment (emergency flotation gear or another optional installation) was installed on the aircraft between April 24, 1995 and August 31, 1996.

Requirement: To ensure that there is no loss of electrical continuity, accomplish the following:-

1. Inspect the circuit breakers and replace if necessary per Eurocopter SB 01.00.47.
2. Remove from service all circuit breakers listed in the applicability section of this AD.

(DGAC AD 1998-511-074 refers)

Compliance: 1. Inspect within next 200 hours TIS or by 12 June 1999, whichever is the sooner. For those circuit breakers held as spares, inspect before installation.

2. Replace by 1 January 2000.

Effective Date: 12 March 1999**DCA/AS350/52B Tail Rotor Hub Pitch Change Plate Bearings - Inspection****Applicability:** AS 350 helicopters, versions: B, BA, BB, B1, B2, B3 and D fitted with tail rotor hub pitch change plate, P/Ns 350A33-2004-00, -01, -02, -03, -05 or 350A33-2009-00, -01 that do not incorporate MOD 076551 (new generation bearing P/N 6010F234M16 (704A33.651.190) introduced by AS 350 SB 65.00.38 R1)**Requirement:** To prevent seizure of the tail rotor hub pitch change plate bearings and loss of control of the helicopter, accomplish the following:-

1. Check the rotation torque of the bearing per paragraph 2.B 1) of Eurocopter AS350 ASB 05.00.29.
2. Inspect for axial play, friction point and brinelling per paragraph 2.B 2) of Eurocopter AS350 ASB 05.00.29.
3. Check any pitch change plate assemblies held as spares per paragraph 2.B 1) b) and 2.B 2) of Eurocopter AS350 ASB 05.00.29.

If the measured rotational load is greater than 300 grams, remove the pitch change plate assembly from the aircraft or do not install if the assembly as held as a spare.

If the measured rotational load is less than 300 grams, and if the axial play is greater than or equal to 0.4mm and/or friction points or brinelling are detected:

Check the condition of the parts (excluding the pitch change plate bearing) and replace them per paragraph 2.B 3) b) of Eurocopter AS350 ASB 05.00.29.

Replace the pitch change plate bearing with a bearing in airworthy condition.
(DGAC AD 1999-085-076R3 refers)

- Compliance:**
1. Unless already accomplished, within the next 10 hours TIS or 14 days, whichever is the sooner.
 2. Within next 10 hours TIS and thereafter at intervals not to exceed 50 hours TIS or 6 months whichever is the sooner.
 3. Before installing a pitch change plate assembly or a tail rotor gear box assembly held as spare.

Effective Date: DCA/AS350/52A - 10 June 1999
DCA/AS350/52B - 17 December 1999

DCA/AS350/53 NR Indicator Lighting - Modification

Applicability: AS 350B3 that do not incorporate MOD 072810 or any other approved modification enabling full NR indicator lighting in normal and emergency mode.

Requirement: To ensure lighting of the NR indicator by the emergency lighting power supply, modify per Eurocopter AS 350 SB 33.00.17.
(DGAC AD 1999-512-077 refers)

Compliance: By 24 May 2000

Effective Date: 24 February 2000

DCA/AS350/54A Tail Rotor Pitch Change Rotating Plates – Inspection and Modification

Applicability: AS 350 aircraft, versions B, BA, BB, B1, B2, B3, and D fitted with tail rotor pitch change rotating plates all P/Ns, which have not had MOD 07 6554 embodied.

Requirement: To prevent rotation of the bearing spacers and the inner bearing race of the tail rotor pitch change plate, which may cause excessive wear and cut the rotating plate and result in loss of pitch control of the tail rotor, accomplish the following:

1. Mark the position of the spacer and the tail rotor pitch change rotating plate, per paragraph 2.B.1. of Eurocopter AS 350 ASB 05.00.33 R1 or later revision.
2. Inspect the paint index marks on the tail rotor pitch change rotating plate and on the spacer for alignment, per paragraph 2.B.2. of ASB 05.00.33. If the paint index marks are not aligned, accomplish paragraph 2.B.4. per ASB 05.00.33 within the next 25 hours TIS.
3. Embody MOD 07 6554 per paragraph 2.B.3. of ASB 05.00.33.
(DGAC F-2000-222-079R1 refers)

Note 1: This AD does not apply to aircraft fitted with pitch change plate assembly P/N 350A33-2030-00 (MOD 076550).

Note 2: Before installing any pitch change plate assembly or a tail gear box assembly held as spares, accomplish paragraph 2.B.3. per AS 350 ASB 05.00.33 (embodiment of MOD 07 6554).

Note 3: The inspection detailed in requirement 2 may be accomplished by the pilot in accordance with CAR Part 43, Appendix A. The pilot must be trained and authorised (Part 43, Subpart B refers) and certification must be provided (Part 43, Subpart C refers).

Compliance:

1. Within next 10 hours TIS, unless previously accomplished.
2. After the last flight of the day.
3. Within 400 hours TIS after 15 June 2000.

Effective Date: DCA/AS350/54 - 15 June 2000
DCA/AS350/54A - 28 July 2005

DCA/AS350/55 Engine Oil Tank Breather Pipe - Fireproofing

Applicability: AS 350 helicopters, versions: B, B1, B2, BA, BB and D which have not had MOD 07 2793 embodied.

Requirement: Fireproof the engine oil tank breather pipe, by fitting a heat-resistant silicone sheath per paragraph 2 of Eurocopter AS 350 SB 79.00.11 Rev 1.
(DGAC AD 2000-268-078 refers)

Compliance: By 31 December 2000

Effective Date: 27 July 2000

DCA/AS350/56 Ferry Fuel Tanks - Electrical Bonding

Applicability: AS 350 B, BA, B1, B2, B3, BB and D helicopters equipped with metal ferry fuel tanks, P/N 330A 871310 .00, .01, .02, .03 and .04.

Requirement: To prevent the generation an electrostatic spark between the re-fueling nozzle and the ferry fuel tank caused by the absence of this electrical bonding and possible explosion of the fuel tank, accomplish the electrical bonding per Eurocopter Service Telex AS 350 No. 28.00.14, paragraph C.C.

(DGAC AD 2000-302 refers)

Compliance: For ferry fuel tanks which are already installed on a helicopter, before the next re-fueling. For ferry fuel tanks which are not installed on a helicopter before installation.

Effective Date: 27 July 2000

DCA/AS350/57B Tail Rotor Drive Shaft Forward Fairing - Inspection

Applicability: AS 350B3 helicopters equipped with forward fairing P/N 350A.23.0032.09 pre Mod 073097.

AS 350B3 helicopters equipped with forward fairing P/N 350A23.1075.00 post Mod 073097.

Requirement: To prevent separation of the tail rotor drive shaft forward fairing heat shield and possible loss of control of the helicopter, accomplish the following:-

1. P/N 350A23.0032.09 without the repair 350-53-42-00 or pre mod 073097

1.1 Before the first flight and at each check after the last flight of the day (ALF check):

a) Visually check the fairing in the 6 areas of attachment to the heat shield per Eurocopter AS 350 ASB 05.00.35.

b) In case of detection of a crack or in case of doubt about the presence of crack, apply the instructions of paragraphs 1.2 a) and 1.2 b) below.

1.2 Within 50 hours TIS and thereafter at intervals not exceeding 50 hours TIS:

a) After removal of the fairing, visually check the internal face of the fairing in the 9 areas of attachment to the heat shield per paragraph 2.B.1 of the ASB.

b) In case of detection of a crack and before the next flight, discard the fairing or repair it, if the repair criteria in paragraph 2.B.1 of the ASB are not exceeded, per repair sheet 350 53 42 00 (crack stop and 3 stiffeners setting).

2. P/N 350A23.0032.09 with repair 350-53-42-00

2.1 At each check after the last flight of the day (ALF check):

a) Visually check the fairing in the 6 areas of attachment to the heat shield per paragraph 2.B.2 of Eurocopter AS350 ASB 05.00.35.

b) In case of propagation of an existing crack out of the crack stop or in case of a new crack or in case of doubt, before the next flight and after removal the

fairing, visually check the stiffeners and the external face of the fairing under the heat protection per paragraph 2.B.1 of the Telex Service.

c) In case of presence of a crack in one or more stiffeners or in case of propagation of an existing crack out of the crack stop or in case of detection of a new crack on the fairing, discard the fairing.

2.2 Every 100 hours TIS and after removal of the fairing:

a) Visually check the stiffeners and the external face of the fairing under the heat protection per paragraph 2.B.1 of the ASB.

b) In case of presence of a crack in one or more stiffeners or in case of propagation of an existing crack out of the crack stop or in case of detection of a new crack on the fairing discard the fairing.

3. Fairing P/N 350A23.1075.00 with the Modification 073097

3.1 At each check after the last flight of the day (ALF check):

a) Visually check the fairing in the 6 areas of attachment to the heat shield per paragraph 2.B.2 of Eurocopter AS350 ASB 05.00.35.

b) In case of doubt of existing cracks, before the next flight and after removal the fairing, visually check the stiffeners and the external face of the fairing under the heat protection per paragraph 2.B.1 of the ASB.

c) In case of presence of a crack, discard the fairing.

3.2 Every 100 hours TIS and after removal of the fairing:

a) Visually check the stiffeners and the external face of the fairing under the heat protection per paragraph 2.B.1 of the ASB.

b) In case of presence of a crack, discard the fairing.

4. Replacement Fairing P/N 350A23.0032.09

4.1 Embody Mod 073097 before installing a tail rotor drive shaft forward fairing P/N 350A23.0032.09.

(DGAC AD 2000-340-080R2 refers).

Compliance: Compliance is required at the times specified within the requirement of this airworthiness directive.

Note: The daily inspections may be accomplished by the pilot in accordance with CAR Part 43, Appendix A. The pilot must be trained and authorised (Part 43, Subpart B refers) and certification must be provided (Part 43, Subpart C refers).

Effective Date: DCA/AS350/57A - 26 October 2000
DCA/AS350/57B - 28 February 2002

DCA/AS350/58 Tail Rotor Hub Pitch Change Plate Bearings - Replacement

Applicability: AS 350, versions B, BA, BB, B1, B2, B3 and D fitted with tail rotor pitch change plate SNR bearing, P/N 6010F234M16 (704A33-651-190).

Requirement: To prevent failure of the tail rotor hub pitch-change bearings and subsequent loss of control of the helicopter, replace tail rotor pitch change plate bearings, P/N 6010F234M16 (704A33-651-190) at the compliance times specified below. (DGAC AD 2001-074-081 refers)

Compliance: (a) AS 350 B3 version:

For bearings with less than 270 hours TTIS, replace no later than 300 hours TTIS.

For bearings with between 270 and 600 hours TTIS, replace within the next 30 hours TIS.

For bearings with between 600 and 900 hours TTIS, replace within the next 20 hours TIS.

For bearings with 900 hours or higher TTIS, replace within the next 10 hours TIS.

Thereafter, bearing life is not to exceed 300 hours TTIS.

(b) AS 350 B, BA, BB, B1, B2 and D versions:

For bearings with less than 1150 hours TTIS, replace no later than 1200 TTIS.

For bearings with between 1150 and 1550 hours TTIS, replace within the next 50 hours TIS.

For bearings with 1550 hours or higher TTIS, replace within the next 10 hours TIS.

Thereafter, bearing life is not to exceed 1200 hours TTIS.

(c) Transfer of bearings between AS 350 versions:

If bearings are to be transferred from one AS 350 version to another, apply the transfer rules per Master Servicing Manual, Chapter 05.99, Page P8.

Effective Date: 15 March 2001

DCA/AS350/59 Cancelled – DCA/AS350/108 refers

Effective Date: 27 March 2008

DCA/AS350/60 Engine Indication System – Resistor Installation

Applicability: AS 350B3 helicopters delivered new before 1 May 1999 or containing ASU No 2 circuit boards, P/N SE 03022 (704A47720110), that were manufactured before 1 May 1999.

Requirement: To ensure the correct functioning of the BATT.TEMP, ENGINE CHIP and the rotor rpm signal output to the VEMD, accomplish the following:-

Determine if the resistor R8 is installed on the ASU No 2-circuit board, per paragraph 2.B of Eurocopter SB 77.00.07. If the resistor is not fitted, replace the circuit board with a serviceable item.

(DGAC 2001-319-083 refers)

Compliance: Within 50 hours TIS

Inspect all uninstalled boards prior to installation.

Effective Date: 30 August 2001

DCA/AS350/61A Cancelled – DGAC AD 2001-557-086R3 refers

Effective Date: 27 June 2019

DCA/AS350/62 Cancelled – DCA/AS350/74 refers

Effective Date: 30 October 2003

DCA/AS350/63B Tail Servo Control Eye End Fitting – Inspection and Rework

- Applicability:** Model AS350 B, BA, B1, B2, B3, BB and D aircraft fitted with all types and all P/N tail servo controls except those aircraft embodied with modification 073139 or those aircraft embodied with Eurocopter AS350 SB No. 67.00.22.
- Note:** DCA/AS350/63B revised to clarify the AD requirement when no play is detected and the lockwasher is found correctly installed in the tail servo control coupling with no change to the AD requirement. The repetitive inspection interval revised to 500 hours TIS. A repetitive inspection per DCA/AS350/63B may be deferred for a period of not more than 10% of the AD inspection interval to allow the inspection to be carried out during other scheduled maintenance (CAA Rule Part 39.55 refers).
- Requirement:** To prevent the progressive reduction of the servo yaw control range which could cause loss of servo control power assistance, inspect the eye end fitting to servo control coupling locking, per the instructions in paragraph 2.A. of Eurocopter AS350 Alert Service Bulletin (ASB) No. 05.00.37 revision 1 or later approved revisions.
- If no play is found and the lockwasher is correctly installed, then the aircraft may be returned to service. If any play is detected and/or the lockwasher is not correctly installed, accomplish the corrective actions per paragraph 2.B. of ASB No. 05.00.37 before further flight.
(DGAC AD F-2001-580-085R2 refers)
- Compliance:** At 500 hours TTIS or within the next 50 hours TIS whichever occurs later, unless previously accomplished within the last 500 hours TIS, and thereafter at intervals not to exceed 500 hours TIS.
- Effective Date:** DCA/AS350/63A - 28 June 2007
DCA/AS350/63B - 30 August 2012

DCA/AS350/64 Engine Control Switch – Inspection

- Applicability:** AS 350 B3 delivered before 15 October 2001 and equipped with engine control switching unit P/N 200192.
- Requirement:** To prevent ingress of water, which may freeze, and jam the engine control switching unit preventing manual engine governing, inspect the unit for watertightness per Eurocopter AS 350 ASB 76.00.16. If water is discovered comply with paragraphs 2.B.2a and S.B.3 of the ASB. If no water is discovered apply sealing procedure as described in paragraph 2.B.3 of the ASB.
(DGAC 2001-548-084 refers)
- Compliance:** Within next 100 hours TIS or before next flight into freezing conditions whichever occurs first.
- Effective Date:** 20 December 2001

DCA/AS350/65 Hydraulic Cut-Off Control - Modification

- Applicability:** Model AS 350B helicopters with S/N less than 1525.
- Requirement:** To prevent accidental or uncommanded cut-off of the hydraulic system, modify the electrical connection to hydraulic cut-off push button on the pilot's collective lever, per Aerospatiale SB 29.01. This SB is not included in the current publication list, but is available from Eurocopter International Pacific, NZ Ltd.
- Note:** If the hydraulic cut-off push button switch shows any signs of wear, it is recommended that the switch be renewed while accomplishing this modification.
- Compliance:** By 31 August 2002
- Effective Date:** 28 February 2002

DCA/AS350/66 Cancelled - DCA/AS350/94 refers**Effective Date:** 16 August 2006**DCA/AS350/67 HSI - Inspection****Applicability:** AS 350 B, BA, B1, B2, B3, BB and D equipped with HSI KI 525A.**Requirement:** To prevent navigation errors due to incorrect installations of the HSI KI 525A P/N 066-3046-07, accomplish the following:

Check the part number of HSI KI 525A installed on aircraft. If the P/N is 066-3046-07, comply with the instructions given in Eurocopter AS 350 Alert Telex No. 34.00.13.

(DGAC AD 2002-281-091 refers)

Compliance: Within 100 hours TIS or by 28 July 2002, whichever occurs first.**Effective Date:** 27 June 2002**DCA/AS350/68 Hawker Pacific TRW-SAMM Main Servocontrols - Replacement****Applicability:** AS 350 B3 helicopters equipped with TRW-SAMM main servo controls P/N SC 8042 or SC 8043 which underwent their last complete overhaul or repair at Hawker Pacific Aerospace, USA, before 1 March 2002.**Requirement:** To prevent incorrect tightening torque on the end-fitting that attaches the servo control cylinder to the upper ball end-fitting from causing separation of the upper end-fitting and loss of the control of the helicopter, remove the subject servo controls and return them to Hawker Pacific Aerospace for a check of the thread condition and application of the tightening torque per Eurocopter AS 350 Alert Telex No. 67.00.23.

(DGAC AD 2002-314-069 refers)

Compliance:

Servo control TTIS (hours)	Replace before (whichever occurs first)
less than 1000	next 550 hours TIS or by 27 June 2003
1000 - 1300	1,550 hours TTIS or by 28 March 2003
1300 or more:	next 250 hours TIS or by 28 Dec 2002

Effective Date: 27 June 2002**DCA/AS350/69 Eurocopter Canada Collective Lock - Replacement****Applicability:** Model AS350BA and B2 helicopters, modified with a Eurocopter Canada Limited (ECL) Left-Side Pilot Configuration kit in accordance with Canadian STC SH96-32 or United States STC SR00429 NY.**Requirement:** To prevent inadvertent engagement of the collective control locking device, and subsequent loss of control of the helicopter, accomplish the following:

Replace the collective control locking device with a redesigned locking device in accordance with ECL AS350 BA, B2 Service Bulletin No. ECL-99-67-002, Revision 2.

(FAA AD 2002-04-07 refers)

Compliance: Within 50 hours TIS or by 31 July 2002, whichever occurs first.**Effective Date:** 27 June 2002**DCA/AS350/70 Cancelled – EASA AD 2019-0228 refers****Effective Date:** 26 September 2019

DCA/AS350/71 Cyclic Friction Cup - Inspection

- Applicability:** AS 350 helicopter versions B, BA, B1, B2, B3, BB and D, modified per MOD 070682 (AS 350 SB No. 67.09), and before embodiment of MOD 073179.
- Requirement:** To eliminate the risk of binding in the cyclic stick "nose-up" control stop position configuration, due to the lower friction cup causing interference with the trimming edge of the friction bowl, measure the cyclic stick bowl-lower friction cup overlap in compliance with the instructions described in EUROCOPTER AS 350 Alert Telex (AT) No. 67.00.24 R1. If the overlapping is not correct, within the next 2 months, replace the cup in compliance with the instructions described in paragraph 2.B.2 of the referenced AT.
(DGAC AD 2003-002 refers)
- Compliance:** By 28 February 2003, and thereafter each readjustment of the cyclic stick longitudinal nose-up control stop.
- Effective Date:** 30 January 2003

DCA/AS350/72 Dynamic Components – Life Correction

- Applicability:** AS 350 B, BA, BB, B1, B2, B3 and D, equipped with dynamic components following overhaul (RG) or repair (RE) at the EUROCOPTER helicopter maintenance and overhaul facility (D.E.R.H.), listed in Tables 1 and 2 (as applicable) of paragraph 3 "APPENDIX" of the Alert Telex referenced below.
- Requirement:** To prevent life limited dynamic components from exceeding their life limits due to a miscalculation of their operating hours at the time of repair or overhaul at the Eurocopter overhaul and maintenance center (D.E.R.H) listed in Alert Telex 62.00.25, accomplish the following:
1. With reference to the equipment log cards (FME) determine whether any of the helicopter's dynamic components embody parts affected by this directive, IAW the instructions of paragraph 2.B.1 of the Alert Telex. If a check reveals that no components are affected, no further action is required.
 2. If affected parts are fitted, correct the operating hours IAW the instructions of Paragraph 2.B.2 of the Alert Telex. If after correction, the operating hours of a part exceed its life limit, remove the part from service. Comply with paragraph 2.B.2 of the Alert Telex before installing dynamic components or parts held as spares that have undergone repair or overhaul.
(DGAC AD 2002-452R1 refers)
- Compliance:**
1. Within 10 Hours TIS
 2. Within 50 Hours TIS
- Effective Date:** 29 May 2003

DCA/AS350/73A Battery Lug - Inspection

- Applicability:** AS 350 B, BA, BB, B1, B2, B3 and D, pre-MOD 073226
- Requirement:** To prevent a short circuit which may cause a complete loss of electrical power, inspect the battery lug in accordance with Eurocopter AS 350 ASB 24.00.10.
(DGAC AD 2003-260R1refers)
- Compliance:** Within 50 hours or by 31 August 2003 whichever occurs first.
- Effective Date:** 31 July 2003

DCA/AS350/74 TRW-SAMM Servo Controls - Replacement

Applicability: AS350 B, BA, B1, B2, B3 BB and D equipped with the following main and tail TRW SAMM servo controls:

A.	<u>P/N</u>	<u>S/N</u>
	SC5083:	1500 through 1515.
	SC5084	722 through 726.
B.	<u>P/N</u>	<u>S/N</u>
	SC5081-1:	78, 89, 227, 240, 315, 362, 427, 451, 452, 492, 497, 498, 506, 512, 532, 550, 556, 561.
	SC5082-1:	045, 180, 194, 197, 254, 264.
	SC5083:	01, 03, 05, 082, 17, 21, 40, 43M, 65M, 77, 87, 103M, 106M, 107, 109, 128, 129, 138, 139, 144, 148, 152, 206, 207, 218, 221, 226, 235, 239, 240, 241, 243, 254, 256, 269, 286, 287, 290, 291, 302, 312, 321, 325, 327, 330, 331, 334, 338, 339, 347M, 356M, 365, 371, 372, 378M, 380M, 389, 412M, 418, 423, 428, 439, 484M, 503, 505, 525, 526, 528, 529, 573M, 587, 594M, 598, 612, 622, 1150 to 1155, 1157, 1159 to 1169, 1180 to 1199, 1207, 1208, 1210 to 1259, 1269, 1291 to 1499.
	SC5084:	013, 025, 31, 75, 087, 87, 101M, 102, 105, 108, 136, 160, 162, 165M, 203, 205, 205M, 209, 220, 225, 232M, 239M, 267M, 271, 288M, 292, 300, 320, 364M, 458, 612, 627, 630, 632 to 634, 636 to 652, 654, 656 to 660, 682 to 721, 727 to 731, 733 to 756.
	SC5071-1:	343, 389.
	SC5072:	003, 35, 108, 197, 216M, 253M, 339M, 347M, 432M, 700 to 724, 726 to 744, 763 to 768, 783 to 789, 820 to 883.

Note: Servo controls with part numbers with suffix "V" have been checked or repaired by TRW SAMM. These servocontrols are exempt from the actions of this AD.
(DGAC AD F-2003-099 refers)

Requirement: Due to a quality control problem, the above servo controls may be non-airworthy and must be removed from service. Inspect to determine S/N of servo controls and replace any affected servo controls with serviceable units.
(DGAC AD 2003-099 and Eurocopter AS350 ASB 01.00.52 refer)

Compliance: Servo controls with S/N in list A, before further flight.
Servo controls in list B, within 550 hours TIS or by 30 October 2005 whichever occurs first.

Effective Date: 30 October 2003

DCA/AS350/75A Flight Control Stops – Inspection and Modification

Applicability: Model AS 350 B, BA, BB, B1, B2, B3 and D aircraft which are not fitted with MOD 073206 or MOD 073102.

Requirement: To prevent loosening of the flight control stops which may restrict the travel of the flight controls, accomplish the following:

1. Check the flight control stop positions and adjust, if necessary, per paragraph 2.B.1 of Eurocopter AS 350 ASB 67.00.25 revision 1 or later.
2. Double lock the flight control stop adjusting screws as per paragraph 2.B.2 of ASB 67.00.25.

(DGAC AD F-2003-322R1 refers)

Compliance:

1. Within 100 hours TIS.
2. Within 500 hours TIS.

Effective Date: DCA/AS350/75 - 30 October 2003
DCA/AS350/75A - 28 July 2005

DCA/AS350/76 Collective Lever Lock – Inspection

Applicability: AS 350 B, BA, BB, B1, B2, B3 and D fitted with the pilot collective lever locking system: Locks PN 350A77.1309.xx and 350A27.3155.20.

Requirement: To prevent uncommanded collective control inputs, check for wear on the collective lever lock by measuring the dimension "C" on the collective lever per paragraph 2.B.2 of Eurocopter AS 350 ASB 67.00.27. Any defects found must be rectified before further flight.

(DGAC AD 2003-406 refers)

Compliance: Within the next 50 hours TIS.

Effective Date: 27 November 2003

DCA/AS350/77 Fuel Bleed Lever - Modification

Applicability: AS 350 B, BA, BB, B1, B2, B3 and D, pre-MOD 073239.

Requirement: To prevent the possible loss of the fuel bleed lever in flight, which may result in damage to the tail rotor, remove and modify the fuel bleed lever per Eurocopter AS 350 ASB No. 28.00.16.

(DGAC AD F-2004-033 refers)

Compliance: Within next 100 hours TIS.

Effective Date: 25 March 2004

DCA/AS350/78 Rear Fuselage - Inspection

Applicability: AS 350 B, BA, BB, B1, B2, B3 and D pre-MOD 073215, or **not** equipped with the four reinforcement angles, P/Ns 350A08.2493.20 / .21 / .22 / .23, following repair per MRM Work Card 53.10.22.772.

Requirement: To prevent loss of the helicopter due to cracking of the tail boom junction frame accomplish either part 1 or part 2 as applicable:

1. For aircraft **not equipped** with two reinforcement angles on the RH side of the rear frame per the repair defined on MRM Work Card 53.10.22.772:
 - a. Comply with paragraph 2.B.1.A of Eurocopter AS 350 ASB No. 05.00.43.
 - b. inspect the RH side of the rear frame per the instructions described in paragraph 2.B.1.B of the referenced ASB.

c. If there is a crack in the rear frame, of length less than or equal to 30 mm, comply with the instructions in paragraph 2.B.1.B of the referenced ASB, at intervals not exceeding 110 hours TIS.

d. If there is a crack in the rear frame, more than 30 mm long, carry out the repair per MRM Work Card 53.10.22.772, no later than within 110 hours TIS, if all the cracks are less than or equal to 50 mm, or before further flight, if one or more crack is greater than 50 mm long.

2. For aircraft **equipped** with two reinforcement angles on the RH side of the rear frame per the repair defined on MRM Work Card 53.10.22.772:

Comply with paragraph 2.B.2 of the referenced ASB. If there is a crack in the reinforcement angles, replace the frame per the instructions described in paragraph 2.B.2 of the referenced ASB before further flight.

(DGAC AD F-2004-035 refers)

Compliance: Before accumulating 2700 hours TIS or within 100 hours TIS whichever is the later and thereafter at intervals not to exceed 550 hours TIS.

Effective Date: 25 March 2004

DCA/AS350/79 Tail Rotor Control Cable - Replacement

Applicability: AS 350 B, BA, BB, B1, B2, B3 and D fitted with tail rotor control cable P/N 704A34-130-058 or P/N 704A34-130-068.

Requirement: To prevent binding or seizing of the tail rotor control cable and subsequent loss of control of the helicopter, replace cables P/N 704A34-130-058 and P/N 704A34-130-068 per Eurocopter SB 67-00-26.

(DGAC AD F-2005-042 refers)

Compliance: Before further flight following any report by the pilot of tail rotor control binding or by 22 October 2004, whichever is the sooner.

Effective Date: 22 April 2004

DCA/AS350/80A Cancelled – DCA/AS350/112 refers

Effective Date: 12 December 2008

DCA/AS350/81 Hydraulic System Cut-off- Modification

Applicability: AS 350 B, B1, B2, B3, BA, BB and D, pre-Mod 073263

Requirement: To prevent a possible load imbalance in the flight controls due to residual fluid trapped after shutting off the hydraulic assistance, modify the electrical system in accordance with Eurocopter AS350 ASB 29.00.07.

(DGAC AD F-2004-089 refers)

Compliance: Before 31 December 2004

Effective Date: 30 September 2004

DCA/AS350/82 Cancelled - DCA/AS350/98 refers

Effective Date: 28 September 2006

DCA/AS350/83 Tail Rotor Blade Trailing Edge Tab – Inspection and Modification

Applicability: All model AS350 B, BA, BB, B1, B2, B3 and D aircraft, fitted with tail rotor blades with P/Ns as listed in the following table and which have not been repaired per Repair Sheet No 238 or Work Card 64.10.00.872.

Part Numbers:	Serial Numbers:
355A 12.0040 all dash numbers	8400 through 9224
355A 12.0050.04	8400 through 9224

Requirement: To prevent the failure of tail rotor blade trailing edge tab due to debonding and subsequent increase in the vibration level of the aircraft, accomplish the following:

1. Install additional rivets on the trailing edge tab of blades as per instruction 2.B. in Eurocopter AS350 ASB 64.00.05.
2. Before installing spare tail rotor blades confirm that additional rivets have been installed on the trailing edge tab of blades as per instruction 2.B. in Eurocopter AS350 ASB 64.00.05.
(DGAC AD F-2004-178 refers)

Compliance:

1. Within 100 TIS or by 28 July 2005, whichever is the sooner.
2. Prior to installation for any affected tail rotor blades.

Effective Date: 28 April 2005

DCA/AS350/84B Cancelled - DCA/AS350/99 refers

Effective Date: 28 September 2006

DCA/AS350/85 Cancelled – DCA/AS350/86 refers

Effective Date: 29 September 2005

DCA/AS350/86 Cancelled - DCA/AS350/97 refers

Effective Date: 28 September 2006

DCA/AS350/87 Breeze Eastern 450-lb Electric Hoist - Inspection

Applicability: Model AS 350 B3 aircraft, fitted with a Breeze Eastern 450 lb. Electric Hoist P/N BL 29700-23.

Requirement: To prevent cable damage caused by malfunction of the up end-of-travel stop mechanism, accomplish the following:

1. Inspect the spring compression of the damper assembly and perform a dimensional check of the damper assembly buffer, per paragraphs 2.B.1.a and 2.B.1.b of Eurocopter AS 350 Alert Service Bulletin AS355 No. 25.00.73.
2. Perform a dimensional check of the damper assembly buffer, per paragraph 2.B.1.b of ASB 25.00.73.
3. Check the hook in the up position, per paragraph 2.B.2 of ASB 25.00.73.
(DGAC AD F-2002-027-088R1 refers)

Compliance:

1. Before the next hoisting mission and on each installation of a hoist in the helicopter.
2. Every 50 hoisting cycles or 3 months, whichever occurs first.
3. Every day that the hoist is to be used.

Effective Date: 1 December 2005

DCA/AS350/88 Cancelled – DCA/AS350/91 refers**Effective Date:** 1 June 2006**DCA/AS350/89 Main Servo Controls – Inspection and Replacement****Applicability:** Model AS 350 B, AS 350 BA, AS 350 BB, AS 350 B1, AS 350 B2, AS 350 B3 and AS 350 D aircraft, fitted with main servo-controls, all P/Ns not modified per MOD 073343, andOn which the tightening torque of the nut that secures the upper ball-end has been increased following the embodiment of MOD 073191, or

Compliance with MET Work Card 67.30.00.402 since MET Revision 04-06.

Requirement: To detect cracks in the tapered housing of a main servo-control, which in time could lead to the loss of the attachment of the servo-control to the non-rotating swashplate, and subsequent loss of aircraft control, accomplish the following:

1. Inspect the tapered housings of the main servo-controls for cracks, per the instructions specified in paragraph 2.B.2. of Eurocopter AS 350 Alert Service Bulletin (ASB), No. 05.00.51.

If no cracks are found, comply once with the tightening torque instructions per paragraph 2.B.3. of ASB No. 05.00.51, before further flight. No further action is required.

2. If a crack is found, accomplish the following:

a) If the crack is vertical along the servo-control axis and is less than 20 mm long comply once with the tightening torque instructions per paragraph 2.B.3. of ASB No. 05.00.51 and identify the end of the crack using an indelible ink marker, before further flight.

Inspect for crack growth per the instructions in paragraph 2.B.4. of the ASB No. 05.00.51.

b) If the crack is vertical along the servo-control axis and is 20mm or longer, or the crack has grown by more than 5mm, or there is an oblique or a horizontal crack, or there are several cracks, replace the servo-control per the instructions in paragraph 2.A. of ASB No. 05.00.51, before further flight.

(EASA AD 2006-0055-E refers)

Note 1: Before installing a main servo-control held as spares, comply with the instructions per paragraph 2.B.2.b. of ASB No. 05.00.51. If no cracks are evident, comply once with the instructions per paragraph 2.B.3. of ASB No. 05.00.51. If a crack is evident, return the servo-control to Eurocopter for repair.**Note 2:** The replacement of cracked servo-controls per the instructions in paragraph 2.A. of ASB No. 05.00.51, is a terminating action to the requirements of this AD.**Compliance:**

1. Within the next 10 hours TIS, or by 16 March 2006, whichever is the sooner.
- 2.a) At every ALF-check inspect for crack growth, without exceeding 10 hours TIS between two inspections, and replace cracked servo-controls within 150 hours TIS or by 6 June 2006 or if crack growth exceeds 5mm, whichever occurs first. (ALF-Check: Check after last flight of the day.)
- 2.b) Before further flight.

Effective Date: 7 March 2006

DCA/AS350/90 Cancelled – DCA/AS350/109 refers**Effective Date:** 28 August 2008**DCA/AS350/91 Cancelled – DCA/AS350/109 refers****Effective Date:** 28 August 2008**DCA/AS350/92 Cancelled – DCA/AS350/126 refers****Effective Date:** 26 January 2012**DCA/AS350/93 Twist Grip Solenoid – Inspection, Operation and Replacement****Applicability:** All AS 350 B3 aircraft with twist grips MOD 073084 embodied and solenoid MOD 073222 not embodied.**Note:** This AD is not applicable to aircraft fitted with the Arriel 2B1 engines and with modification 073261 embodied.**Requirement:** To prevent twist grip seizure and loss of the emergency governing function due to prolonged use of the emergency governing function, causing overheating of the solenoid and seizure of the twist grip locking pin, accomplish the following:

1. Inspect the solenoid, per the instructions in paragraph 2.B.1 of Eurocopter AS 350 Alert Service Bulletin (ASB) No. 05.00.44.
2. Operate the aircraft per paragraph 2.B.3 of ASB No. 05.00.44 when carrying out governor failure training or in the event of actual governor failure.

Operate the aircraft when maintenance operations are performed that require the "AUTO/MAN" governing mode selector to be held in the "MAN" position, per paragraph 2.B.2 of ASB No. 05.00.44.

If the operating time of the solenoid has exceeded 15 consecutive minutes, or if a waiting time of at least 15 minutes between two operations was not observed (even if the solenoid has operated only for a few minutes), or if the emergency governing function has been subjected to prolonged use due to an actual governor failure, the solenoid shall be replaced, per the instructions in paragraph 2.B.3 of ASB No. 05.00.44, before the next flight.

(EASA AD 2006-0183-E refers)

- Compliance:**
1. Before the first flight of the day, until embodiment of Mod 07322 is accomplished.
 2. With effect from 11 July 2006, until embodiment of Mod 07322 is accomplished.

Effective Date: 11 July 2006**DCA/AS350/94 Cancelled – DCA/AS350/103 refers****Effective Date:** 18 May 2007**DCA/AS350/95 Cancelled - DCA/EMY/27 refers****Effective Date:** 30 November 2006

DCA/AS350/96A Tail Rotor Servo Control – Inspection and Rework

Applicability: Model AS 350 B3 aircraft fitted with a Goodrich tail servo-control P/Ns SC5071-XX or SC5072 except:

Tail rotor servo-controls P/N SC5072, S/N 1372 onward, or
Tail rotor servo-controls overhauled or repaired per Goodrich Service Bulletin No. SC507X-67-39-01-3, or
Tail rotor servo-controls that have never been removed since aircraft manufacture.

Requirement: To prevent restricted travel of the tail rotor control pedals, which could lead to side slip of the helicopter in an autorotation flight at VNE, accomplish the following:

1. Intentional auto-rotation is prohibited until the tail rotor servo-control system has been inspected per requirement 2.

Note: Requirement 1 may be accomplished by inserting a copy of this AD in the AFM.

2. For helicopters not fitted with an Automatic Flight Control System accomplish the instructions in paragraph 2.B.2.a. of AS 350 ASB No. 67.00.30. For helicopters fitted with an Automatic Flight Control System accomplish the instructions in paragraph 2.B.2.b. of AS 350 ASB No. 67.00.30.

If the travel of the tail rotor servo-control is not within limits per paragraph 2.B.6. of AS 350 ASB No. 67.00.30, replace the tail rotor servo-control per the instructions in paragraph 2.B.3 and 2.B.2 of AS 350 ASB No. 67.00.30.

3. Before replacing tail rotor servo-controls, comply with the instructions specified in paragraph 2.B.6. of AS 350 ASB No. 67.00.30. (EASA AD 2006-0247 refers)

Compliance:

1. From the effective date of this AD.
2. Within 50 hours TIS, unless already accomplished.
3. At every replacement of the tail rotor servo-control.

Effective Date: DCA/AS350/96 - 18 September 2006
DCA/AS350/96A - 28 September 2006

DCA/AS350/97B Cancelled – DCA/AS350/106 refers

Effective Date: 27 September 2007

DCA/AS350/98 Sliding Door Rollers and Rails – Inspection and Modification

Applicability: Model AS 350 B, BA, BB, B1, B2, B3 and D aircraft fitted with sliding doors not modified per MOD 073287 and/or MOD 073290.

Requirement: To prevent loss of the sliding door in flight, due to the possibility of sliding door rollers and rail wear, inspect the diameter of the roller and the dimensions of the front end opening of the middle rail, per the instructions in paragraph 2.B.1 of Eurocopter AS 350 Alert Service Bulletin (ASB) No. 05.00.41, revision 2.

According to the criteria defined in paragraph 2.B.1 of AS 350 ASB No. 05.00.41 accomplish the following actions per paragraph 2.B.2 of AS 350 ASB No. 05.00.41:

- If $C1 > 5$ mm and $C2 > 1.5$ mm: Door opening in flight is permitted.
- If $C1 < 5$ mm and/or $C2 < 1.5$ mm: Door opening in flight is prohibited.

If $C1 < 5$ mm and/or $C2 < 1.5$ mm, then fix a '**Door Opening in Flight is Prohibited**' placard on the instrument panel of the aircraft.

Note 1: Before installing sliding doors held as spares, accomplish the requirements of this AD.

Note 2: Embodiment of MOD 073287 and/or MOD 073290, per Eurocopter AS 350 Service Bulletin No. 52.00.29 is a terminating action to the requirements of this AD. (EASA AD 2006-0249 refers)

Compliance: Before further flight, unless already accomplished, and thereafter at intervals not to exceed 100 hours TIS.

Effective Date: 28 September 2006

DCA/AS350/99 RH Cabin Vibration Damper and Blade Assy – Inspection and Modification

Applicability: All model AS 350 B, BA, BB, B1, B2, B3 and D aircraft fitted with an automatic flight control system and a right hand cabin vibration damper blade (all P/Ns) with MOD 073325 not embodied.

Requirement: To prevent the failure of the blade of the cabin vibration damper assembly, which could lead to the failed part interfering with the trim actuator rod, resulting in the jamming of the flight controls accomplish the following:

1. Inspect the visible areas of the cabin vibration damper assembly blade for cracks, per paragraph 2.B.1. of Eurocopter AS 350 Alert Service Bulletin No. 05.00.48.

Replace cracked blades per paragraph 2.B.1. of AS 350 ASB No. 05.00.48, before further flight.

2. Modify the cabin vibration damper and blade assembly by fitting a containment casing assembly, per the instructions in paragraph 2. of AS 350 ASB No. 53.00.34.

Note 1: After blade replacement, continue inspecting the blades for cracks, per requirement 1 at every daily post flight inspection, until accomplishment of requirement 2.

Note 2: Sign logbook for compliance with requirement 1 at time of raising the aircraft technical log.

Note 3: Accomplishment of requirement 2 (MOD 073325) is a terminating action to the requirements of this AD.

Note 4: This AD is applicable to AS 350 aircraft fitted with an automatic flight control system modified per MODs 072262, 071543 and OP1055. (EASA AD 2006-0273 refers)

Compliance: 1. At every daily post flight inspection.
2. By 30 June 2007.

Effective Date: 28 September 2006

DCA/AS350/100 Starter Generator – Load Limitation

Applicability: Model AS 350 B3 aircraft fitted with APC 200 A starter generators P/N 200SGL130Q and not embodied with MOD 073345, and

All model AS 350 aircraft fitted with APC 200 A starter generators P/N 200SGL130Q.

Note: All model AS 350 aircraft are included in the applicability because APC 200 A starter generators P/N 200SGL130Q may have been fitted to these aircraft under a New Zealand modification approval.

Requirement: To prevent excessive power consumption of the starter generator reducing the engine surge margin which could result in engine failure, the current draw for APC 200 A starter generators is limited to 180 Amp.

Install a label indicating this load limitation on the instrument panel below the VEMD, per the instructions in paragraph 2.B. of Eurocopter AS 350 Alert Service Bulletin No. 01.00.57.

(EASA AD 2006-0337 refers)

Compliance: Within the next 100 hours TIS or by 30 November 2007, whichever occurs sooner.

Effective Date: 30 November 2006

DCA/AS350/101 Yaw Control Load Compensator Lever – Inspection

Applicability: All model AS 350 B1 and AS 350 B2 aircraft.

Requirement: To prevent restricted travel of the yaw control due to the possibility of the incorrect part being fitted to the aircraft, which could lead to loss of aircraft control, inspect the aircraft log book to determine whether the yaw control load compensator lever has been replaced.

- a) If the load compensator lever has never been replaced, or if the load compensator lever was replaced with P/N 355A27-0072-00, no further action is required.
- b) If the P/N is 355A27-0082-00, contact the manufacturer for further instruction.
- c) If it cannot be determined whether the load compensator lever has been replaced, or if the load compensator lever P/N cannot be determined, inspect the aircraft to determine the P/N of load compensator lever, within the next 10 hours TIS, per the instructions in paragraph 2.B. of Eurocopter AS 350 Alert Service Bulletin (ASB) No. 67.00.39.

(EASA AD 2006-0363-E refers)

Note: Yaw control load compensator levers P/N 355A27-0082-00 may not be fitted to AS 350 B1 or AS 350 B2 aircraft.

Compliance: Before further flight.

Effective Date: 7 December 2006

DCA/AS350/102 Main & Tail Rotor Servo Controls – Inspection and Rework

Applicability: Model AS 350 aircraft, all S/N

Fitted with Goodrich main or tail rotor servo-controls with the following P/N and S/N with no letter "R" marked in the inspection box of the servo-control identification plate:

P/N SC8042, S/N 1590, 1591, 1592, 1593, 1616 or 1618.

P/N SC8043, S/N 865, 866, 867 or 881.

Requirement: To prevent the incorrect installation of the servo-control cap from not mechanically limiting the rotation of the distributor, which could result in loss of aircraft rotor control, accomplish the following:

1. Inspect the aircraft and/or the aircraft log books to verify the P/N and S/N of the main rotor and tail rotor servo-controls in accordance with the instructions in paragraph 1.A of Eurocopter AS 350 Alert Service Bulletin (ASB) No. 67.00.40.
2. Replace all affected servo-controls per the instructions in paragraph 2.B. of AS 350 ASB No. 67.00.40.

Note: Affected servo-controls may not be fitted to any aircraft unless they have been returned to conformity per the instructions in paragraph 2.B. of AS 350 ASB No. 67.00.40.

(EASA AD 2007-0099 refers)

Compliance: 1. By 31 July 2007.

2. At the next removal of the servo-controls or by 31 May 2009, whichever is the later.

Effective Date: 31 May 2007

DCA/AS350/103C Tail Rotor Blade Skin – Inspection and Repair

Applicability: Model AS 350 B, BA, BB, B1, B2, B3 and D aircraft, all S/N fitted with tail rotor blades P/N:

- 355A12-0031-01/ -02/ -03/ -04/ -05/ -06/ -07/ -08/ -09/ -11/ -12/ -13/ -14, and
- 355A12-0040-00/ -01/ -02/ -03/ -04/ -05/ -07/ -08, and
- 355A12-0050-04.

Note 1: This AD supersedes DCA/AS350/103B with no change to the requirement. This AD revised to introduce EASA AD 2009-0039 as reference.

Requirement: To prevent tail rotor blade skin separation causing significant imbalance and possibly resulting in loss of aircraft control, accomplish the following:

1. Visually inspect the blade face in zone A, per the instructions specified in paragraph 2.B.1. of Eurocopter AS 350 Alert Service Bulletin (ASB) No. 05.00.40, revision 3 or later approved revisions.

If the tail rotor blade skin is cracked in zone A, comply with the instructions specified in paragraph 2.B.2. of AS 350 ASB No. 05.00.40, before further flight.

Note 2: The visual inspection may be accomplished by the pilot in accordance with CAR Part 43, Appendix A. The pilot must be trained and authorised (Part 43, Subpart B refers) and certification must be provided (Part 43, Subpart C refers).

Note 3: Sign log book for requirement 1 compliance at time of raising tech log.

2. For tail rotor blades P/N 355A12-0050-00/-01/-02/-03/-04/-05 with S/N listed per paragraph 2.B.2.a. of AS 350 ASB No. 05.00.40, embody Repair Sheet (FR) CN 376 or (FR) CN 453.

For tail rotor blades with S/N below 8419, with annotation “repaired as per Work Card 64.10.00.872” or “repaired as per Work Card 64.10.20.712” recorded on the log card, embody Repair Sheet (FR) CN 376 or (FR) CN 453.

3. Affected tail rotor blades shall not be fitted to any aircraft unless the instructions in paragraph AS 350 ASB No. 05.00.40 is accomplished.

Note 4: Accomplishing (FR) CN 376 on affected tail rotor blades per AS 350 ASB No. 05.00.40 revision 2 is acceptable to comply with requirements 2 and 3 of this AD. (EASA AD 2009-0039 refers)

- Compliance:**
1. After the last flight of the day without exceeding 10 flight hours between each check.
 2. By 5 April 2009, unless previously accomplished.
 3. From 5 March 2009.

Effective Date: DCA/AS350/103A - 25 September 2008
DCA/AS350/103B - 29 January 2009
DCA/AS350/103C - 5 March 2009

DCA/AS350/104 Cabin Floor Cross Member – Inspection and Rework

Applicability: Model AS350 B, BA, BB, B1, B2, B3 and D aircraft, all S/N delivered before 1 January 2007 and fitted with a collective-to-yaw control coupling with or without an Automatic Flight Control System.

Requirement: To prevent a cracked cabin floor cross member at X2325 possibly resulting in reduced ability to control aircraft yaw, accomplish the following:

1. Inspect the aircraft and establish whether the cross-member at station X 2165 and the doublers at stations X 2325 and Y 269 are installed per Eurocopter AS 350 Alert Service Bulletin (ASB) No. 53.00.37.

If a cross-member and doublers are installed, no further action is required.

If a cross-member and/or doublers are not installed, inspect for cracks per AS 350 ASB No. 53.00.37.

If no cracks are found inspect the tail rotor control rigging per AS 350 ASB No. 53.00.37, before further flight. Tail rotor control rigging only required to be accomplished at the initial visual inspection.

If any cracks are found accomplish a manufacturer approved repair scheme, before further flight.

2. Install a cross-member at station X 2165 and doublers at stations X 2325 and Y 269, in accordance with the instructions in AS 350 ASB No. 53.00.37.

(EASA AD 2007-0139-E refers)

- Compliance:**
1. Within the next 10 hours TIS or by 18 June 2007, whichever occurs sooner, and thereafter at intervals not to exceed 50 hours TIS until accomplishment of requirement 2.
 2. By 18 May 2008.

Effective Date: 18 May 2007

DCA/AS350/105 Main & Tail Rotor Servo Controls – Inspection and Replacement

Applicability: Model AS 350 B, BA, BB, B1, B2, B3 and D aircraft, all S/N,

Fitted with Goodrich main rotor servo-controls with the following P/N and S/N with no letter “C” marked in the inspection box of the servo-control identification plate:

P/N SC5083, S/N 270M, 272M, 409M, 423M, 452M or 1573, P/N SC5083-1, S/N 2902 through to 2921, P/N SC5084, S/N 30, 84, 104, 186, 438, 575 or 695, P/N SC5084-1, S/N 1462 through to 1481, or

Fitted with Goodrich tail rotor servo-controls with the following P/N and S/N with no letter “C” marked in the inspection box of the servo-control identification plate:

P/N SC5072, S/N 222M, 306M or 309.

Requirement: To prevent the distributor slide valve jamming on its sleeve due to the possibility of excessive play in the servo control input lever bearing which could result in reduced rotor control, accomplish the following:

1. Inspect the aircraft and/or the aircraft log books to verify the P/N and S/N of the main rotor and tail rotor servo-controls in accordance with the instructions in paragraph 1.E.2. of Eurocopter AS 350 Alert Service Bulletin (ASB) No. 01.00.58 revision 1. If an affected servo-control is fitted to the aircraft, accomplish a flight control system check per section 4 of the AFM to establish that no “hard points” exist in the flight controls.

If any “hard point” is detected in the flight controls, replace the defective servo-control(s) per the instructions in paragraph 2.B. of AS 350 ASB No. 01.00.58, before further flight.

2. Replace all affected servo-controls per the instructions in paragraph 2.B. of AS 350 ASB No. 01.00.58.

(EASA AD 2007-0141-E refers)

Note: Affected servo-controls may not be fitted to any aircraft unless they have been returned to conformity per the instructions in paragraph 2. of AS350 ASB No. 01.00.58.

- Compliance:**
1. Before further flight, and if an affected part is fitted to the aircraft inspect thereafter at every pre-flight inspection, until accomplishment of requirement 2.
 2. Within the next 50 hours TIS or by 24 September 2007, whichever occurs sooner.

Effective Date: 24 May 2007

DCA/AS350/106 Sliding Door Rear Fitting and Support Shaft – Inspection and Replacement

Applicability: Models AS 350 B, AS 350 BA, AS 350 BB, AS 350 B1, AS 350 B2, AS 350 B3 and AS 350 D, all S/N fitted with sliding door(s) without MOD 073298 and/or MOD 073308 embodied.

Note: This AD supersedes DCA/AS350/97B with the inclusion of requirement 3 and 4.

Requirement: To detect cracks in the rear roller support shaft and the rear fitting of the sliding door, accomplish the following:

1. Inspect the sliding door support shaft and rear fitting, per paragraph 2.B in Eurocopter AS 350 Alert Service Bulletin (ASB) No. 05.00.47.

If cracked, replace per paragraph 2.B in AS 350 ASB No. 05.00.30, before further flight.

2. Modify sliding doors, per paragraph 2.B in AS 350 ASB No. 52.00.30.

3. Before installing sliding doors listed in paragraph 1.A.2 of ASB No. 52.00.30 revision 1 embody MOD 073298 and/or MOD 073308 per the instructions in AS 350 ASB No. 52.00.30.

4. Rail roller pins P/N 350A25-1275-20 and cast roller support fittings P/N 350A25-1270-20 and P/N 350A25-1270-22 shall not be fitted to any aircraft.

(EASA AD 2007-0236 refers)

Compliance: 1. At 100 hours TTIS or within 20 hours TIS whichever is the later, unless already accomplished and thereafter at intervals not to exceed 100 hours TIS.

2. By 31 December 2007.

3. & 4. From 27 September 2007.

Effective Date: 27 September 2007

DCA/AS350/107 Collective Lever Recess - Modification

Applicability: Model AS 350 B, AS 350 B1 and AS 350 D aircraft not embodied with MOD 071995.

Requirement: To prevent foreign material possibly restricting the collective pitch control travel which could result in loss of aircraft control, accomplish the following:

1. Modify the collective lever per the instructions in paragraph 2.B. of Eurocopter Alert Service Bulletin (ASB) No. 67.00.16 revision 2.

2. Covers P/N 350A27-1385-20 shall not be fitted to any aircraft.

(EASA AD 2007-0289 refers)

Compliance: 1. Within the next 550 hours TIS or by 29 November 2008 whichever occurs sooner.

2. From 29 November 2007.

Effective Date: 29 November 2007

DCA/AS350/108 Rear Bench Seat Cushions – Removal or Modification

Applicability: Model AS 350 B, BA, BB, B1, B2, B3 and D models fitted with a rear bench seat not embodied with modification 073166 per Eurocopter AS 350 Service Bulletin No. 25.00.70.

Note 1: This AD supersedes DCA/AS350/59 and includes modification 073166 (per AS 350 SB No.25.00.70) as a terminating action to the requirements of this AD.

Requirement: To prevent in-flight loss of rear bench seat cushions and possible impact with the main or tail rotor and subsequent loss of aircraft, revise the Limitations Section of the Aircraft Flight Manual (AFM) to include the following:

“Before any flight with the door(s) removed or the sliding door(s) open, remove the cushions from the rear bench seat, unless the seat is to be occupied.”

Note 2: This requirement may be accomplished by inserting a copy of this AD in the AFM or by incorporating a manufacturer’s flight manual revision that contains the wording per this AD. Operators must ensure that pilots are aware of this flight manual revision.

Note 3: The embodiment of modification 073166 per AS 350 SB No.25.00.70 is a terminating action to the requirements of this AD. (EASA AD 2008-0044 refers)

Compliance: By 27 April 2008.

Effective Date: 27 March 2008

DCA/AS350/109 Cancelled – DCA/AS350/114 refers

Effective Date: 23 February 2009

DCA/AS350/110 Aerazur Emergency Flotation Gear - Inspection and Replacement

Applicability: Model AS350 BA aircraft, all S/N fitted with emergency flotation gear including LH container assembly P/N 158170 or 158210-1 and RH container assembly P/N 158171 or 158215-1 for which a non-recurring service life extension has not been granted by Aerazur.

Requirement: To prevent an emergency flotation gear container from remaining in service beyond the safe operating service life limit, accomplish the following:

1. Replace container assemblies per Eurocopter ASB No. 25.01.02 revision 0 dated 24 September 2008 or later approved revisions.
2. A container assembly manufactured 10 years or more ago shall not be fitted to any aircraft unless the emergency flotation gear is returned to the equipment manufacturer for examination and the issue of a non-recurring service life extension.
3. A container assembly shall not be fitted to any aircraft or remain in service if the non-recurring service life extension granted by the equipment manufacturer has expired.

Note: A non-recurring service life extension can be obtained from Aerazur by returning the emergency flotation gear to them for inspection.

(EASA AD 2008-0189 refers)

Compliance:

1. For container assemblies that were manufactured 12 or more years ago:
By 30 November 2008, and
For container assemblies that were manufactured between 10 and 12 years:
By 30 December 2008 or 145 months (12 years and 1 month) since the container date of manufacture, whichever occurs sooner, and
For container assemblies that were manufactured between 9 and 10 years:
By 122 months (10 years and 2 months) since the container date of manufacture, and

For container assemblies that were manufactured less than 9 years ago:

By 120 months (10 years) since the equipment date of manufacture, and
Thereafter at intervals not to exceed 10 years.

2. From 30 October 2008
3. From 30 October 2008

Effective Date: 30 October 2008

DCA/AS350/111A **Cancelled – DCA/AS350/115 refers**

Effective Date: 26 February 2009

DCA/AS350/112 Emergency Flotation Gear – Inspection, Placard and Replacement

Applicability: Model AS350 B, AS350 BA and AS350 D aircraft, all S/N fitted with emergency flotation gear.

Note: This AD supersedes DCA/AS350/80A and introduces a conformity inspection of the fixed and removable parts of the emergency flotation gear.

Requirement: To prevent insufficient weight carrying capability of the emergency flotation gear which could result in aircraft instability or aircraft loss in the event of a ditching, accomplish the following:

1. Inspect the emergency flotation gear for conformity per paragraph 2.B.1. in Eurocopter ASB No. 01.00.59 revision 0 dated 20 November 2008 of later approved revisions.

For aircraft fitted with flotation gear limited to 1900 kg and the fixed and removable parts of the emergency flotation gear are found compliant, the maximum permissible aircraft weight for flights over water is limited to 1900 kg. Install the applicable placard on the instrument panel indicating the maximum permissible aircraft weight for flights over water, per paragraph 2.B.2. of ASB No. 01.00.59.

For AS350 B and AS350 D aircraft fitted with flotation gear limited to 1950 kg and the fixed and removable parts of the emergency flotation gear are found compliant, the maximum permissible aircraft weight for flights over water is the maximum permissible weight of the aircraft. (Refer to the AFM to determine the maximum permissible weight of the aircraft).

For AS350 BA aircraft fitted with flotation gear limited to 1950 kg and the fixed and removable parts of the emergency flotation gear are found compliant, the maximum permissible aircraft weight for flights over water is limited to 1950 kg. Install the applicable placard on the instrument panel indicating the maximum permissible aircraft weight for flights over water, per paragraph 2.B.2. of ASB No. 01.00.59.

For aircraft fitted with flotation gear limited to 2600 kg and the fixed and removable parts of the emergency flotation gear are found compliant, the maximum permissible aircraft weight for flights over water is the maximum permissible weight of the aircraft. (Refer to the AFM to determine the maximum permissible weight of the aircraft).

If the fixed and removable parts of the emergency flotation gear are found non-compliant and if any of the gear parts are limited to 1900 kg, the maximum aircraft weight for flights over water is limited to 1900 kg. Install the applicable placard on the instrument panel indicating the maximum permissible aircraft weight for flights over water, per paragraph 2.B.2. of ASB No. 01.00.59.

For AS350 BA aircraft if the fixed and removable parts of the emergency flotation gear are found non-compliant and neither of the parts are limited to 1900 kg, the maximum aircraft weight for flights over water is limited to 1950 kg. Install the applicable placard on the instrument panel indicating the maximum permissible aircraft weight for flights over water, per paragraph 2.B.2. of ASB No. 01.00.59.

2. For aircraft fitted with non-compliant emergency flotation gear, return the gear to an acceptable configuration by either replacing the non compliant removable part with

another part which conforms with the fixed part, or by replace the non-compliant fixed part with another part which conforms with the removable part per ASB No. 01.00.59.

3. Emergency flotation gear shall not be fitted to any aircraft unless the configuration conforms to the requirements in paragraph 2.B.1. of ASB No. 01.00.59. (EASA AD 2008-0214-E refers)

Compliance:

1. Within the next 15 hours TIS.
2. By 12 December 2009.
3. From 12 December 2008.

Effective Date: 12 December 2008

DCA/AS350/113 Cancelled – DCA/AS350/116 refers

Effective Date: 4 March 2009

DCA/AS350/114 Fin Attach Fittings – Inspection, Modification & Replacement

Applicability: Model AS 350 B, AS 350 B1, AS 350 B2, AS 350 B3, AS 350 BA, AS 350 BB and AS 350 D helicopters, all S/N fitted with the following upper and lower fins without modification 073330 embodied:

Upper fin assembly P/N: 350A14-0020-00XX, 350A14-0020-01XX, 350A14-0020-02XX, 350A14-0020-03XX, 350A14-0020-08XX, 350A14-0020-09XX, 350A14-0020-10XX, 350A14-0020-17XX, 350A14-0020-18XX, 350A14-0020-19XX and 350A64-1144-00XX, and

Lower fin assembly P/N: 350A14-0021-00XX, 350A14-0021-01XX, 350A14-0021-02XX, 350A14-0021-03XX and 350A14-0021-04XX.

Note 1: This AD retains the requirements of superseded DCA/AS350/109, introduces additional affected fin assemblies in the applicability, and reintroduces the omitted initial requirement and repetitive inspections previously required by DCA/AS350/90.

Requirement: To prevent failure of the upper and lower fin attachment fittings due to fatigue, which could result in loss of the vertical fin, accomplish the following:

1. For AS 350 B, B1, B2, BA, BB and D helicopters:

Remove the fins and embody modification 073330 per Eurocopter AS 350 Alert Service Bulletin No. 55.00.16 Revision 1 dated 05 January 2009 or later approved revisions.

2. For AS 350 B3 helicopters without upper fin MOD 073148 embodied and without MOD 073288 embodied:

Replace the upper and lower fin attachment screws and embody modification 073288 per paragraph per paragraph 2.B.1 and 2.B.2 of Eurocopter AS 350 Alert Service Bulletin No. 55.00.13 revision 2 dated 28 February or later approved revisions.

3. For AS 350 B3 helicopters without upper fin MOD 073148 embodied and with MOD 073288 embodied:

Check the tightening torque of the upper fin attachment screws and check the upper fin reinforcement splice for cracks and loosened rivets per paragraph 2.B.3 of AS 350 ASB 55.00.13.

If cracks or loose rivets in the reinforcement splice are found, or if the tightening torque of one or both of the attachment screws is less than 80% of the minimum torque value, accomplish the corrective actions per paragraph 2.B.3.a.1, 2.B.3.a.2. or 2.B.3.a.3. as applicable, of AS 350 ASB 55.00.13 before further flight.

4. For all AS 350 B3 helicopters:

Remove the upper and lower fins and embody modification 073330 per AS 350 ASB No. 55.00.16.

5. An affected upper or lower fin shall not be fitted to any aircraft unless embodied with modification MOD 073330 per AS 350 ASB No. 55.00.16.

Note 2: Accomplishment of requirement 4 of this AD is a terminating action for the repetitive inspections of requirement 3.

Note 3: With the embodiment of modification 073330 the lower and upper fittings bolts P/N 22126BV060032L and washers P/N 23112AG060LE are replaced with special bolts P/N 350A23-4016-20 and special washers P/N 350A23- 4017-22.
(EASA AD 2009-0030 refers)

Compliance:

1. By 15 April 2009.
2. Within the next 15 hours TIS unless already accomplished.
3. For aircraft with more than 100 hours TIS since the last inspection:
Within the next 15 hours TIS and thereafter at intervals not to exceed 100 hours TIS.
For aircraft with less than 100 hours TIS since the last inspection:
Within 100 hours TIS since the last inspection and thereafter at intervals not to exceed 100 hours TIS.
4. By 15 April 2009 unless previously accomplished.
5. From 23 February 2009.

Effective Date: 23 February 2009

DCA/AS350/115B Collective Lever Lock – Inspection and Rework

Applicability: Model AS350 B, AS350 BA, AS350 BB, AS350 B1, AS350 B2, AS350 B3 and AS350 D aircraft embodied with modification 073237 per Eurocopter SB No. 67.00.37 revision 0 or revision 1.

Model AS350 B, AS350 BA, AS350 BB, AS350 B1, AS350 B2, AS350 B3 and AS350 D aircraft not embodied with modification 073175.

Model AS350 B, AS350 BA, AS350 BB, AS350 B1, AS350 B2, AS350 B3 and AS350 D aircraft on which the locking studs, or the collective pitch levers, or the locking strips have been reworked or modified in service.

Model AS350 B, AS350 BA, AS350 BB, AS350 B1, AS350 B2, AS350 B3 and AS350 D aircraft, S/N 3972, 3973, 3982, 3987, 4003, 4023, 4046, 4050, 4086, 4120, 4122, 4132, 4143, 4152, 4172, 4194, 4259, 4314, 4324, 4378, 4392, 4447, 4452, 4477, 4489, 4490, 4501, 4523, 4546, 4560, 4589, 4594, 4599, 4632, 4659, 4666 and 4671.

Note 1: Review the aircraft records/logbooks to determine the helicopter/collective lever configuration and AD applicability.

Note 2: This AD revised to clarify the compliance. There is no change to the AD requirement.

Requirement: To prevent inadvertent engagement of the collective control locking device which could result in loss of aircraft control, accomplish the following:

1. For aircraft embodied with modification 073237:

Measure the clearance between the end of the locking stud and the locking strip in accordance with paragraph 2.B.2.a. of Eurocopter ASB No. 05.00.58 revision 0 dated 1 December 2008, or later approved revisions.

If the clearance is equal to or more than 3 mm return the aircraft to service.

If the clearance is less than 3 mm on aircraft not embodied with modification 073175, accomplish the instructions of paragraph 2.B.2.b. of ASB No. 05.00.58 before further flight.

If the clearance is less than 3 mm on aircraft embodied with modification 073175, accomplish the instructions of paragraph 2.B.2.c. of ASB No. 05.00.58 before further flight.

2. For aircraft not embodied with modification 073237:

Measure the clearance between the end of the locking stud and the locking strip in accordance with paragraph 2.B.3.a. of ASB No. 05.00.58.

If the clearance is equal to or more than 3 mm return the aircraft to service.

If the clearance is less than 3 mm on aircraft not embodied with modification 073175, accomplish the instructions of paragraph 2.B.3.b. of ASB No. 05.00.58.

If the clearance is less than 3 mm on aircraft embodied with modification 073175, accomplish a manufacturer approved repair before further flight.

(EASA AD 2009-0019 refers)

Note 3: If required one ferry flight is permitted with no passengers on board to reposition the aircraft to a base where the requirements of this AD can be accomplished.

Compliance:

1. Initial compliance: After the last flight of the day.
Repetitive compliance: At intervals not to exceed 600 hours TIS or 24 months whichever occurs sooner, and every time the collective pitch lever, the locking stud or the locking strip is replaced, and every time the locking strip setting is readjusted.

2. Initial compliance: After the last flight of the day.

Repetitive compliance: At intervals not to exceed 600 hours TIS or 24 months whichever occurs sooner, and every time the collective pitch lever, the locking stud or the locking strip is replaced, and every time the locking strip setting is readjusted.

Effective Date: DCA/AS350/115 - 26 February 2009
DCA/AS350/115A - 17 December 2009
DCA/AS350/115B - 8 December 2011

DCA/AS350/116 Starter Generator Damping Assembly – Adjustment and Marking

Applicability: Model AS 350 B, BA, BB, B1, B2 and B3 aircraft, all S/N fitted with an Arriel engine and an Aircraft Parts Corporation (APC) starter generator P/N 150SG122Q or P/N 200SGL130Q without a “004” mark on the data plate.

Note: This AD supersedes DCA/AS350/113 and introduces a new adjustment procedure to improve the performance of the APC starter generator damping assembly.

Requirement: To prevent failure of the 41 tooth pinion in the engine accessory gear box due to an inoperative starter generator torque damping system which could result in loss of engine power, accomplish the following:

1. Adjust and mark the APC starter generator per the instructions in paragraph 2.B.2 of Eurocopter AS350 ASB No. 80.00.07 revision 1 dated 06 February 2009 or later approved revisions.

2. An affected starter generator shall not be fitted to any aircraft unless it has been adjusted and marked per AS350 ASB No. 80.00.07.

(EASA AD 2009-0027 refers)

Compliance:

1. Within the next 100 hours or by 4 June 2009, whichever occurs sooner.
2. From 4 March 2009.

Effective Date: 4 March 2009

DCA/AS350/117 Cancelled – EASA AD 2013-0061 refers

Effective Date: 25 March 2013

DCA/AS350/118 Cancelled – EASA AD 2010-0006 refers

Effective Date: 31 October 2013

DCA/AS350/119 Cancelled – DCA/AS350/120 refers

Effective Date: 9 March 2011

DCA/AS350/120 Tail Gearbox Control Lever – Inspection, Rework and Replacement

Applicability: Model AS 350 B, BA, BB, B1, B2 and D aircraft, all S/N fitted with tail gearbox control levers P/N 350A33-1058-00, 350A33-1058-01, 350A33-1058-02 or 350A33-1058-03 except reinforced control levers P/N 350A33-1524-00 or 350A33-1526-00.

Note 1: This AD retains the requirements in superseded DCA/AS350/119 and introduces a new inspection per Eurocopter ASB 05.00.62 revision 2 dated 28 February 2011. Requirement 3 in this AD introduces an inspection for the opposite rib in affected control levers including those control levers marked with an “X”.

Requirement: To prevent failure of the tail gearbox control lever due to possible induced cracks caused by surface anomalies which could result in reduced aircraft control, accomplish the following:

1. Visual Inspection:

Visually inspect affected control levers per the instructions in paragraph 2.B.1.a of Eurocopter AS350 ASB No. 05.00.62 revision 1, dated 23 April 2010 or later EASA approved revisions.

If any cracks are found contact the manufacturer and replace the affected control lever per the instructions in paragraph 2.B.1.b 2) of Eurocopter AS350 ASB 05.00.62 revision 2, dated 1 March 2011 or later EASA approved revisions.

If no cracks are found accomplish requirement 2 of this AD.

2. No cracks found:

Rework affected control levers per the instructions in paragraph 2.B.3 of AS350 ASB 05.00.62, or replace with a reworked lever (marked with an “X”), or replace with a reinforced control lever P/N 350A33-1524-00 or 350A33-1526-00.

3. New Inspection Requirement:

Visually inspect affected control levers per the instructions in paragraph 2.B.4 of Eurocopter AS350 ASB 05.00.62 revision 2, dated 1 March 2011 or later EASA approved revisions.

If any cracks are found contact the manufacturer and replace the affected control lever per the instructions in paragraph 2.B.1.b 2) of Eurocopter AS350 ASB 05.00.62 revision 2, dated 1 March 2011 or later EASA approved revisions.

4. Rework Requirement:

A tail gearbox control lever with P/N 350A33-1058-00, 350A33-1058-01, 350A33-1058-02 or 350A33-1058-03 shall not be fitted to any aircraft unless it has been reworked (marked with an “X”) per the instructions in of paragraph 2.B.3 of Eurocopter AS350 ASB No. 05.00.62.

Note 2: The repetitive inspections per requirement 1 of this AD may be accomplished by adding the inspection requirements to the tech log. The visual inspection may be performed and certified under the provision in Part 43 Appendix A.1 (7) by the holder of a current pilot licence, if that person is rated on the aircraft, appropriately trained and authorised (Part 43, Subpart B refers), and the maintenance is recorded and certified as required by Part 43.

Note 3: The installation of a reworked lever (marked with an ‘X’) is a terminating action to the repetitive inspections mandated by requirement 1 of this AD.

Note 4: The installation of a reinforced control lever P/N 350A33-1524-00 or 50A33-1526-00 is a terminating action to the repetitive inspections mandated by requirements 1 and 3 of this AD.

(Corrected EASA AD 2011-0038-E refers)

- Compliance:**
1. Within the next 10 hours TIS or after the last flight of the day whichever occurs sooner after 30 April 2010 (the effective date of DCA/AS350/119), and thereafter at intervals not to exceed 10 hours TIS or after the last flight of the day, whichever occurs sooner.
 2. Within the next 660 hours TIS or 14 months whichever occurs sooner after 30 April 2010 (the effective date of DCA/AS350/119).
 3. Before 660 hours TSN or overhaul, or within the next 55 hours TIS for affected TGB control levers with 605 or more hours TSN or overhaul, and thereafter at intervals not to exceed 600 hours TIS.
 4. From 30 April 2010 (the effective date of DCA/AS350/119).

Effective Date: 9 March 2011

DCA/AS350/121 Hydraulic Servo Hoses – Inspection and Rework

Applicability: Model AS 350 B, BA, BB, D, B1, B2 and B3 helicopters, all S/N fitted with a single hydraulic power system and forward (pitch) servo-control hydraulic hoses P/N 704A34-412-033 (or MP/N 675-102-05-01) and P/N 704A34-412-035 (or MP/N 675-102-06-01).

- Requirement:** To prevent an inflight main gearbox compartment fire due to possible hydraulic fluid leaks from the forward hydraulic servo control hoses which could result in loss of main rotor and aircraft control, accomplish the following:
1. Install protection sleeves P/N 706A34-402-225 and P/N 706A34-402-224 on hydraulic hoses P/N 704A34-412-033 and P/N 704A34-412-035 as applicable, per the instructions in paragraph 2.B.2 of Alert Service Bulletin (ASB) No. 29.00.13 revision 0, dated 26 July 2010 or later EASA approved revisions.
 2. Hydraulic hoses P/N 704A34-412-033 and P/N 704A34-412-035 may not be fitted to any helicopter without protection sleeves P/N 706A34-402-225 and P/N 706A34-402-224 as applicable, per the instructions in paragraph 2.B.2 of ASB No. 29.00.13.

Note: Modification 074238 has been introduced on new helicopters at production. This modification satisfies requirement 1 of this AD. (EASA AD 2011-0033 refers)

- Compliance:**
1. By 30 April 2011.
 2. From 31 March 2011.

Effective Date: 31 March 2011

DCA/AS350/122 EASA AD 2011-0072 Cancelled by EASA on 4 March 2022

Effective Date: 4 March 2022

DCA/AS350/123 Tail Gearbox Casing Assembly – Inspection and Replacement

Applicability: Model AS 350 B, BA, BB, B1, B2, B3 and D helicopters, all S/N fitted with TGB casing assembly P/N 350A33-1090-02, S/N MA47577, MA47585, MA47587, MA47588, MA47589, MA47590, MA47591, MA47592, MA47593, MA47597, MA47598, MA47599, MA47600, MA47602, MA47604, MA47606, MA47610, MA47613, MA47615, MA47617, MA47619, MA47620, MA47621, MA47622, MA47623, MA47624, MA47626, MA47628 or MA47631.

Requirement: To prevent loss of tail rotor pitch control due to possible cracks in the TGB control lever attachment yoke which could result in loss of aircraft control, accomplish the following:

1. Review the aircraft records or inspect the aircraft and determine the S/N of the TGB casing assembly P/N 350A33-1090-02. If an affected TGB casing assembly is found fitted, inspect the attachment yoke of the control lever on the TGB casing assembly for cracks per the instructions in paragraph 3 of Eurocopter AS350 ASB 65.00.46 revision 0, dated 18 May 2011 or later approved revisions.

If a crack is found in the control lever yoke on the TGB casing assembly, replace the TGB with a serviceable part per the instructions in AS350 ASB 65.00.46.

2. An affected TGB casing shall not be fitted to any aircraft unless the pitch control lever attachment yokes on the TGB casing assembly have been inspected and found serviceable per the requirements of this AD.

(EASA AD 2011-0104 refers)

- Compliance:**
1. TGB casings with less than 550 hours TSN:
By 30 August 2012 or 660 hours TSN on the TGB casing, whichever occurs sooner.
TGB casings with more than 550 hours TSN:
Within the next 100 hours TIS or by 30 July 2012, whichever occurs sooner.
 2. From 30 June 2011.

Effective Date: 30 June 2011

DCA/AS350/124 Cancelled – EASA AD 2011-0164R1 refers

Effective Date: 28 February 2017

DCA/AS350/125 Cancelled – EASA AD 2013-0281 refers

Effective Date: 11 December 2013

DCA/AS350/126 Cancelled – EASA AD 2012-0252 refers

Effective Date: 12 December 2012

DCA/AS350/127 Fire Detection System – Modification

Applicability: Model AS 350 B2 helicopters, all S/N fitted with a Turbomeca Arriel 1D1 engine and embodied with Eurocopter modification 073273, excluding helicopters embodied with modification 074346.

Requirement: To prevent failure of the engine fire detection system which could result in an undetected engine fire and loss of the aircraft, accomplish the following:
Modify the fire detection system by installing resistor modules 39W and 38W per the instructions in paragraph 3 of Eurocopter AS350 Emergency ASB 26.00.02 dated 23 February 2012 or later approved revisions.
(EASA AD 2012-0033R1 refers)

Compliance: Within the next 40 hours TIS or by 14 May 2012 whichever occurs sooner, unless previously accomplished.

Effective Date: 1 March 2012

The State of Design ADs listed below are available directly from the National Airworthiness Authority (NAA) websites. Links to NAA websites are available on the CAA website at [Links to state of design airworthiness directives | aviation.govt.nz](https://aviation.govt.nz)

If additional NZ ADs need to be issued when an unsafe condition is found to exist in an aircraft or aeronautical product in NZ, they will be added to the list below.

2012-0205 Sliding Door Lower Ball-joint – Modification

Applicability: AS 350 B, AS 350 BA, AS 350 BB, AS 350 B1, AS 350 B2, AS 350 B3 and AS 350 D helicopters, all serial numbers (s/n), and AS 355 E, AS 355 F, AS 355 F1, AS 355 F2, AS 355 N and AS 355 NP helicopters, all S/N, if fitted with sliding doors, except those that embody modification AL. 4262.

Effective Date: 15 October 2012

2012-0207-E Cancelled – EASA AD 2012-0217-E refers

Effective Date: 19 October 2012

2012-0217-E Cancelled – EASA AD 2013-0029 refers

Effective Date: 1 March 2013

2012-0252 Cancelled – EASA AD 2017-0035 refers

Effective Date: 6 March 2017

2012-0257-E Cancelled by EASA AD 2012-0257-CN – Purpose fulfilled

Effective Date: EASA AD 2012-0257-E – 7 December 2012
EASA AD 2012-0257-CN – 25 July 2024

2013-0029 Tail Rotor Laminated Half Bearings – Inspection

Applicability: AS 350 B3 helicopters, all serial numbers, if modified in production by incorporating Eurocopter modification (MOD) 07 5601, except those helicopters that have been modified by incorporating Eurocopter MOD 07 5606 in production.

Note: MOD 07 5601 is an integral part of a specific AS 350 B3 model configuration, commercially identified as “AS350B3e” and is not fitted on AS 350 B3 model helicopters of other configurations

Effective Date: 1 March 2013

2013-0044-E Cancelled – EASA AD 2013-0284-E refers

Effective Date: 4 December 2013

2013-0061 Cancelled – EASA AD 2013-0191-E refers

Effective Date: 23 August 2013

2013-0088 Cancelled – EASA AD 2015-0132 refers

Effective Date: 22 July 2015

2013-0095-E Main/Tail Rotor Servo-Control Bearings – Inspection and Replacement

Applicability: AS 350 B, AS 350 BA, AS 350 BB, AS 350 B1, AS 350 B2, AS 350 B3 and AS 350 D, AS 355 E, AS 355 F, AS 355 F1, AS 355 F2, AS 355 N, AS 355 NP helicopters, all serial numbers, equipped with single hydraulic main and tail servo-controls manufactured by “SAMM”, “TRW”, “GOODRICH”, or “UTAS”

Effective Date: 18 April 2013

2013-0133-CN Cancelled – Purpose fulfilled

Effective Date: 16 February 2016

2013-0191-E Cancelled – EASA AD 2017-0052 refers**Effective Date:** 7 April 2017**2010-0006 Cancelled by EASA on 3 September 2021****Effective Date:** 3 September 2021**2013-0281R1 Position Strobe Light – Inspection****Applicability:** AS 350 B, AS 350 BA, AS 350 BB, AS 350 B1, AS 350 B2, AS 350 B3 and AS 350 D helicopters, all serial numbers (s/n), and AS 355 E, AS 355 F, AS 355 F1, AS 355 F2, AS 355 N and AS 355 NP helicopters, all s/n, if modified in production with (optional) modification OP0811 and equipped with a Grimes-Honeywell power supply unit, Part Number (P/N) 60-1431-3, in the baggage compartment as part of that optional modification, except helicopters that have embodied at least one of the modifications as listed in Appendix1 of this AD.**Effective Date:** 2013-0281 - 11 December 2013
2013-0281R1 - 13 February 2015**2013-0284R1 Cancelled – EASA AD 2014-0233 refers****Effective Date:** 31 October 2014**2013-0287 Cancelled – EASA AD 2021-0195 Refers****Effective Date:** 3 September 2021**2014-0076R3 Cancelled – EASA AD 2022-0051 refers****Effective Date:** 5 April 2022**2014-0132R1 Rotating Star Swashplate – Inspection****Applicability:** AS 350 B, BA, BB, B1, B2, B3 and D helicopters, and AS 355 E, F, F1, F2, N and NP helicopters, and EC130 B4 and T2 helicopters, all serial numbers, if equipped with a swashplate assembly comprising a rotating star with Part Number (P/N) 350A371003-04, P/N 350A371003-05, P/N 350A371003-06, P/N 350A371003-07, or P/N 350A371003-08.**Effective Date:** 2014-0132 - 9 June 2014
2014-0132R1 - 9 June 2014**2014-0233 Hydraulic Pump Bearing - Inspection****Applicability:** AS 350 B, AS 350 BA, AS 350 BB, AS 350 B1, AS 350 B2, AS 350 B3 and AS 350 D helicopters, all serial numbers,
Fitted with single hydraulic system (PRE MOD OP3346 or OP3082) and incorporating Airbus Helicopters, modification 079566 (hydraulic pump drive assembly part number (P/N) 350A35-0132-00 equipped with bearing P/N 704A33651243), or
Modified in service by Airbus Helicopter Alert Service Bulletin (ASB) No. 05.00.72 Rev.04 when the pump drive assembly is equipped with bearing P/N 704A33651243,
Except helicopters which embody modification 079568 (hydraulic pump drive assembly P/N 350A35-0132-01 fitted with bearing P/N 704A33651269).**Effective Date:** 31 October 2014**Transport Canada AD CF-2015-10 STC SR00825NY-D - Hydraulic Test Switch Replacement****Applicability:** Airbus Helicopters (formerly Eurocopter) AS 350 Series Helicopters equipped with Console Upgrade Kits VIA-350-24-001 or -002 in accordance with Supplemental Type Certificate (STC) SR00825NY-D.**Effective Date:** 20 May 2015**2015-0094 Cancelled by EASA on 3 September 2021****Effective Date:** 3 September 2021

DGAC AD 1991-165-058R1 Electric Hoist Bonding – Inspection

Applicability: AS 350 series helicopters specified in DGAC AD 1991-165-058R1 fitted with hoists P/N 76370.010, 76370.011 and 76370.030.

Effective Date: 18 June 2015

2015-0132 Cancelled – EASA AD 2021-0194 Refers

Effective Date: 3 September 2021

2015-0178 Normal Procedures – AFM Amendment

Applicability: AS 350 B3 helicopters, all serial numbers, if fitted with a dual hydraulic system, production modification (mod) OP 3082, or mod OP 3346.

Effective Date: 31 August 2015

2015-0195 Tail Rotor Drive Shaft Bearings – Inspection

Applicability: AS 350 B, BA, BB, B1, B2, B3 and D helicopters, and AS 355 E, F, F1, F2, N and NP helicopters, all serial numbers, if equipped with tail rotor (TR) drive shaft bearings as indicated in Table 1 of this AD.

Effective Date: 7 October 2015

DCA/AS350/128C Forward Two-place Seat - Operating Limitations

Applicability: All AS350 series helicopters fitted with any forward two-place seat, except those helicopters fitted with an Airbus Helicopters forward two-place seat.

Note: The applicability of DCA/AS350/128C revised to exclude helicopters fitted with an Airbus Helicopters forward two-place seat.

DCA/AS350/128B revised to introduce CAA Limitations Section page, dated 30 June 2016, revised to introduce a note. Requirement 2 of this AD revised to introduce the revised limitations page.

Requirement: To prevent a reduction of flight safety from that provided by the manufacturer, accomplish the following:

1. Determine the longitudinal moment arm of the forward two-place seat using the center of the seat pan cushion as a measurement reference point.

Complete and issue a new form CAA 2173 Weight and Balance Data.

The weight of the seat components must be included in the CG calculations. If a seat adaptor plate is fitted the moment (position and weight) of the plate must also be considered for the CG calculation.

The lateral CG arm of the helicopter must not be assumed to be zero. The lateral CG must be recorded and be within the limits specified in the AFM.

Annotate the CAA2173 to include the value of the longitudinal moment arm of the forward two-place seat used.

2. Remove CAA Limitations Section, (1 page), dated 14 December 2015 and insert 1 page dated 30 June 2016.

3.

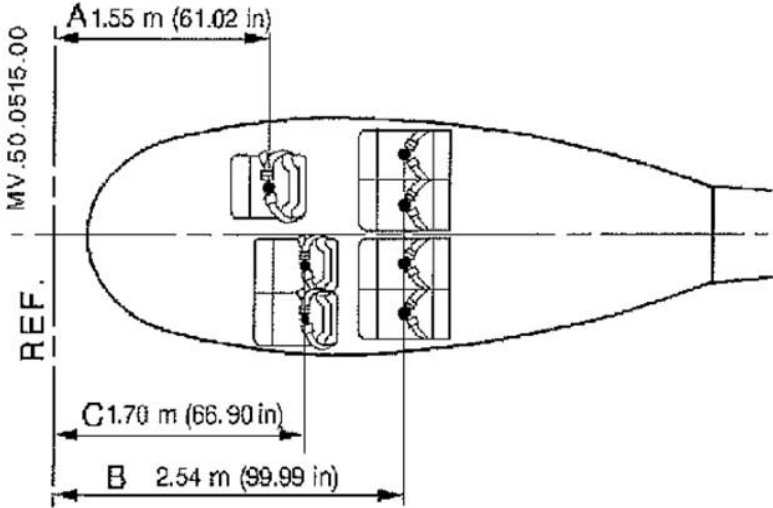

Figure: Airbus Helicopters recommended CG position of forward two-place seat

- Compliance:**
1. Before further use of the forward two-place seat, unless previously accomplished.
 2. Before further use of the forward two-place seat.

- Effective Date:**
- DCA/AS350/128 - 27 November 2015
 - DCA/AS350/128A - 14 December 2015
 - DCA/AS350/128B - 30 June 2016
 - DCA/AS350/128C - 22 March 2018

CAA Approved
AS350 Limitations
30 June 2016

LIMITATION SECTION *

Purpose:

To prevent a reduction of flight safety from that provided by the manufacturer this supplement details the weight and balance limitations for AS350 series helicopters fitted with a forward two-place seat.

Applicability:

All AS350 series helicopters fitted with any forward two-place seat.

Requirements:

Before every flight with occupant(s) or cargo on the forward two-place seat perform a longitudinal and lateral weight and balance calculation in accordance with the AFM and the associated Airbus Helicopters weight and balance procedure. The helicopter center of gravity (CG) must remain within longitudinal and lateral limitations specified in the AFM throughout all phases of flight.

- a. For AS350B and AS350D helicopters the combined weight of the two occupants on the forward two-place seat must not exceed 120kg regardless of longitudinal seat position.
- b. For all other AS350 series helicopters the combined weight of the two occupants on the forward two-place seat must not exceed 154kg regardless of longitudinal seat position.
- c. For all AS350 helicopters the weight of any single occupant seated on the forward two-place seat must not exceed 120kg.

When performing the longitudinal and lateral weight and balance calculation use the center of the seat pan cushion as a measurement reference point for the longitudinal moment arm of the forward two-place seat.

Estimated or standard occupant weights are not acceptable to determine the helicopter CG. Actual occupant weights must be used and recorded for the CG calculation. Where weighing occupants is not practical (i.e. when uplifting passengers in remote locations), the declared passenger weight plus 6kg must be used for weight and balance calculations.

The lateral CG arm of the helicopter must not be assumed to be zero. Lateral CG must be calculated and must remain within the limits prescribed within the AFM.

Note: If the forward two-place seat has only one occupant, then the standard weight for passengers per CAA Rule Part 135.303(b)(2) as determined per CAA Rule Part 135.303(e) may be used for all passengers. The weight of the occupant seated on the forward two-place seat must not exceed 120kg.

* This page is inserted by NZ AD DCA/AS350/128B.

Page 1 of 1

2016-0020 Main Gearbox Casings – Inspection

Applicability: AS 350 B3 helicopters, all serial numbers, if equipped with main gearbox (MGB) main casing Part Number (P/N) 350A32-3156-21 (Fitted on assembly 350A32-3156-01), or P/N 350A32-3156-22 (Fitted on assembly 350A32-3156-02) or P/N 350A32-3121-04 or P/N 350A32-3121-06 or equipped with MGB bottom Casing (sump) P/N 350A32-3119-05.

Effective Date: 5 February 2016

2016-0021 Main Gearbox Bottom Casing – Inspection

Applicability: AS 350 B1, B2 and AS 355 E, F, F1, F2, N helicopters, all serial numbers, if equipped with main gearbox (MGB) bottom Casing (sump) P/N 350A32-3119-03 or P/N 350A32-3119-05.

Effective Date: 5 February 2016

2016-0220 Dual Hydraulic System – Inspection

Applicability: AS 350 B3 helicopters, all serial numbers, if equipped with a dual hydraulic system, except those that embody Airbus Helicopters modification (mod) 074719 and mod 074622.

Effective Date: 18 November 2016

2016-0260 Main Rotor NR Indicator – Inspection

Applicability: AS 350 B2 helicopters, all serial numbers, if equipped with NR sensor Part Number 704A37614007, except helicopters modified in accordance with AH modification 350A084886.00.

Effective Date: 3 January 2017

2017-0020R1 Tail Rotor Pitch Rod – Inspection

Applicability: AS 350 B, AS 350 BA, AS 350 BB, AS 350 B1, AS 350 B2 and AS 350 B3 helicopters, all S/N embodied with modification (mod) 075601 or mod 076602.

Note 1: EASA AD 2017-0020R1 is revised to include requirements for reverting to the original ALS interval for affected pitch rods. Some editorial changes have also been made which does not affect the technical content of the AD.

Note 2: The repetitive inspection requirement per paragraph (1) of EASA AD 2017-0020R1 may be accomplished by adding the inspection to the tech log. The inspection may be performed and certified under the provision in Part 43 Appendix A.1 (7) by the holder of a current pilot license, if that person is rated on the aircraft, appropriately trained and authorized, and the training/authorization is appropriately documented (Part 43, Subpart B refers), and the maintenance is recorded and certified as required by Part 43. If any damage is found in one or more layers of the elastomer with a circumference of more than 90 degrees as detailed in the instructions of the applicable ASB, then an engineer must replace the affected tail rotor pitch change rod with a serviceable part, before further flight.

Effective Date: EASA AD 2017-0020-E - 9 February 2017
EASA AD 2017-0020R1 - 30 May 2019

2011-0164R3 Tail Rotor Control Stop Screws – Inspection

Applicability: AS 350 B, AS 350 BA, AS 350 BB, AS 350 B1, AS 350 B2, AS 350 B3 and AS 350 D helicopters, all S/N fitted with an Autopilot (AP), and AS350 B3 helicopters, all S/N, without an AP installed, but embodied with modification (mod) 073252; except helicopters that have mod 074819 embodied.

Effective Date: EASA AD 2011-0164R1 - 28 February 2017
EASA AD 2011-0164R2 - 28 September 2017
EASA AD 2011-0164R3 - 30 April 2020

2017-0032 Canceled by EASA on 11 August 2021**Effective Date:** 11 August 2021**2017-0035 Twist Grip Assembly – Inspection****Applicability:** AS 350 B3 helicopters, all serial numbers, if equipped with ARRIEL 2B engines.**Effective Date:** 6 March 2017**2017-0052 Canceled – EASA AD 2017-0059 refers****Effective Date:** 13 April 2017**2017-0059 Canceled – EASA AD 2023-0133 refers****Effective Date:** 27 July 2023**2017-0089R1 Main Rotor Mast Upper Bearing - Inspection****Applicability:** AS 350 B, AS 350 BA, AS 350 BB, AS 350 B1, AS 350 B2, AS 350 B3 and AS 350 D helicopters, all S/N.**Note:** This AD revised to introduce an amended OEM ASB to clarify affected parts identification.**Effective Date:** EASA AD 2017-0089 - 31 May 2017
EASA AD 2017-0089R1 - 30 June 2020**2017-0109 (Correction) Starter Generator and Brushes - Inspection****Applicability:** AS 350 B, AS 350 B1, AS 350 BA and AS 350 BB helicopters, all S/N except those helicopters fitted with a Vehicle and Engine Management Display (VEMD) System.

AS 350 B2 helicopters, all S/N

AS 350 B3 helicopters, all S/N, fitted with an ARRIEL 2B engine.

Effective Date: 7 July 2017**2017-0114 Canceled - EASA AD 2020-0186 refers****Effective Date:** 3 September 2020**2017-0143 Direct Current (Optional) Second Battery – Replacement****Applicability:** AS 350 B, AS 350 B1, AS 350 B2, AS 350 B3, AS 350 BA, AS 350 BB and AS 350 D helicopters fitted with a Very Cold Weather Starting Installation (a second battery), except those helicopters embodied with modification 074838 at manufacture.**Effective Date:** 31 August 2017**Transport Canada AD CF-2017-37 Restriction of Directional Control Pedal Movement****Applicability:** Litter kits P/N 350-200034 or P/N 350-200194 (LH litter kits), or P/N 350-200144 (RH litter kit).

These kits could be found installed on Airbus Helicopter models AS 350 B, AS 350 BA, AS 350 B1, AS 350 B2, AS 350 B3, AS 350 D, AS 355 E, AS 355 F, AS 355 F1, AS 355 F2, AS 355 N and AS 355 NP as listed in Tables 1 and 2 of TC AD CF-2017-37.

Effective Date: 19 January 2018

DCA/AS350/129A Cargo Swing Modification OAL114 – Inspection

- Applicability:** All AS350 series helicopters embodied with Oceania Aviation Limited (OAL) cargo swing modification OAL114.
- Note:** DCA/AS350/129A introduces a revised AFM Supplement and a revised ICA for cargo swing modification OAL114.
- Requirement:** To prevent failure of the cargo swing due to possible fatigue cracks in the gimbal / universal joint assembly, which could result in loss of the load, accomplish the following:
1. Revise the AFM and insert OAL AFM Supplement MB 25.00.149, revision 2, dated 30 July 2018, or later approved revision, into the helicopter AFM. Introduce OAL ICA MB 25.00.149 revision 3, dated 19 October 2018, or later approved revision, into the helicopter maintenance programme. Determine that a placard is fitted on the cargo swing frame, per OAL AFM Supplement MB 25.00.149 revision 1, or later approved revision, unless previously accomplished.
 2. Dye penetrant inspect the Gimbal / Universal Joint Assembly P/N OAL114-10500 and P/N OAL114-10504, per the instructions in OAL ICA MB 25.00.149 revision 1, 2 or 3, or later approved revision. Replace defective parts before next hook operation.
- Compliance:**
1. By 25 November 2018.
 2. For bucket operations:
Before the next hook operation (i.e. both agricultural and firefighting operations), unless previously accomplished.
For non-bucket operations:
By 25 November 2018, unless previously accomplished.
- Effective Date:** DCA/AS350/129 - 28 June 2018
DCA/AS350/129A - 25 October 2018

2018-0152 Cancelled – EASA AD 2022-0128 refers

Effective Date: 28 July 2022

2018-0206 Mast Upper Bearing Sealant Bead/Inner Race Retaining Rings - Inspection

Applicability: AS 350 B, AS 350 BA, AS 350 BB, AS 350 B1, AS 350 B2, AS 350 B3 and AS 350 D helicopters, all S/N.

Effective Date: 4 October 2018

FAA AD 2018-18-12 Cancelled – FAA AD 2019-16-16 refers

Effective Date: 26 September 2019

FAA AD 2018-25-17 Air Comm Corp Air Conditioning System – Inspection

Applicability: AS350B, AS350B1, AS350B2, AS350B3, AS350BA, AS350C, AS350D and AS350D1 helicopters fitted with an Air Comm air conditioning system P/N AS350-202-1, AS350-202-2, AS350-202-3, AS350-202-4, AS350-202-5, AS350-204-1, AS350-204- 2, AS350-204-3, AS350-204-4, AS350-204-5, AS350-204-6, AS350-204-7, AS350-204-8, AS350- 204-9, AS350-204-10, AS350-204-11 or AS350-204-12.

Effective Date: 22 January 2019

2018-0287 Cancelled – EASA AD 2019-0060 refers

Effective Date: 3 April 2019

DCA/AS350/130 HETS STC 11/21E/34 – Removal from Service

- Applicability:** All AS350 series helicopters embodied with Aero Design Limited Human External Transport System (HETS) STC 11/21E/34.
- Requirement:** To prevent a reduction of the level of occupant safety from that provided by Transport Canada STC SH98-35, due to mismatched instructions for continuing airworthiness, accomplish the following:
1. Remove Aero Design Limited HETS STC 11/21E/34 from service.
 2. Remove the Flight Manual Supplement (FMS) associated with HETS STC 11/21E/34 from the helicopter AFM.
 3. Remove the Instructions for Continued Airworthiness (ICA) associated with HETS STC 11/21E/34 from the helicopter maintenance programme.
- Note 1:** The equipment approved under revoked HETS STC 11/21E/34 is the same as Transport Canada STC SH98-35. Under the provisions of CAR 21.503(a) the Director has accepted Transport Canada STC SH98-35. Refer to the List of Technical Data accepted by the Director under the provisions of CAR 21.503(a) available on the CAA website.
- Note 2:** In accordance with Rule 21, Appendix D(b)(3) the installer of a foreign STC requires the written permission of the STC holder to install their STC and use the FMS/ICA associated with the STC.
- Compliance:** By 31 March 2019
- Effective Date:** 31 January 2019

Transport Canada CF-2019-01 Helicopter External Transport System (HETS) STC SH98-35

- Applicability:** HETS™ certified under Transport Canada Supplemental Type Certificate (STC) SH98-35, Issue 1 and Issue 2 installed on the following helicopter models:
- Airbus Helicopters (formerly Eurocopter France) model AS 350 B, AS 350 B1, AS 350 B2, AS 350 B3, AS 350 BA and AS 350 D.
- Airbus Helicopters (formerly Eurocopter France) model AS 355 E, AS 355 F, AS 355 F1 and AS 355 F2. MD Helicopter Inc. model 369, 369A, 369H, 369HM, 369HS, 369HE, 369D, 369E, 369F, 369FF and 500N. Bell Helicopter Textron Canada Ltd. model 206B, 206L, 206L-1, 206L-3, 206L-4 and 407.
- Note:** HETS™ approved under SH98-35 are only eligible for installation on helicopter models listed above and they are not eligible for any other models not specifically listed above (Example: not eligible for installation on AS 355 N or AS 355 NP).
- Effective Date:** 22 January 2019

2019-0060 Tail Rotor Gearbox Actuating Rod – Inspection

- Applicability:** AS 350 B, AS 350 BA, AS 350 BB, AS 350 B1, AS 350 B2, AS 350 B3 and AS 350 D helicopters, all S/N.
- Effective Date:** 3 April 2019

DGAC AD 2001-557-086R3 Starflex Star – Inspection

- Applicability:** AS 350 B, AS 350 BA, AS 350 BB, AS 350 B1, AS 350 B2, AS 350 B3 and AS 350 D helicopters, all S/N fitted with a Starflex star P/N 350A31.1916.00 mounted on a main rotor hub not embodied with Mod 076221.
- Note 1:** DGAC AD 2001-557-086R3 supersedes DCA/AS350/61A, which mandated DGAC AD 2001-557-086R2.
- Note 2:** The inspection per mandatory action 3.1 in DGAC AD 2001-557-086R3, which is required after every flight when the rotors are stopped, may be accomplished by adding the inspection requirement to the tech log. The visual inspection may be performed and certified under the provision in Part 43 Appendix A.1 (7) by the holder of a current pilot licence, if that person is rated on the aircraft, appropriately trained, and authorised (Part 43, Subpart B refers), and the maintenance is recorded and certified as required by Part 43.
- Effective Date:** 27 June 2019

2019-0184 Main Rotor Servo Actuators – Inspection

Applicability: AS 350 B3 helicopters, all S/N fitted with a dual hydraulic system OP 3346 or OP 3082.

Effective Date: 29 August 2019

FAA AD 2019-16-16 Inlet Barrier Filter – Inspection

Applicability: AS350B, AS350B1, AS350B2, AS350B3, and AS350BA helicopters fitted with a Pall Aerospace Inlet Barrier Filter (IBF) element P/N CE01301F2, CE01301F2B, CE01303F2, or CE01303F2B.

Effective Date: 26 September 2019

2019-0225-E MGB Drive Shaft / Engine Coupling – Inspection

Applicability: AS 350 B3 helicopters, all S/N fitted with a SAFRAN Helicopter Engines (SAFRAN) ARRIEL 2D engine, having accumulated (on the effective date of this AD) less than 300 hours TIS since first flight.

Effective Date: 13 September 2019

2019-0228 Electric Hoist Installation – Inspection

Applicability: AS 350 B, AS 350 BA, AS 350 BB, AS 350 B1, AS 350 B2, AS 350 B3 and AS 350 D helicopters, all S/N.

Effective Date: 26 September 2019

2019-0280 Spherical Bearing – Inspection

Applicability: AS 350 BB helicopters, all S/N.

Note:

The initial inspection of the spherical bearing elastomer per the AD requirements must be accomplished by an aircraft maintenance engineer. The repetitive inspection per mandatory action (1) in EASA AD 2019-0280, may be accomplished by adding the inspection requirement to the helicopter tech log. The visual inspection may be performed and certified under the provision in Part 43 Appendix A.1 (7) by the holder of a current pilot licence, if that person is rated on the aircraft, appropriately trained, and authorised (Part 43, Subpart B refers), and the maintenance is recorded and certified as required by Part 43. If any defects are found, then an aircraft maintenance engineer must inspect the spherical bearing elastomer and accomplish the corrective actions per EASA AD 2019-0280, before further flight.

Effective Date: 3 December 2019

FAA AD 2020-02-23 Emergency Float System STC SR00470LA – Inspection

Applicability: AS350B, AS350BA, AS350B1, AS350B2, AS350B3, AS350C, AS350D, and AS350D1 helicopters embodied with STC SR00470LA.

Effective Date: 28 February 2020

DCA/AS350/131 Dual Front Seat Modification MB 25.20.05 - Inspection

Applicability: AS350 series helicopters embodied with Ntech Dual Front Seat Modification MB 25.20.05 revisions 0, 1, 2 or 3 before 27 February 2020.

Requirements: To ensure that the helicopter weight and balance limitations are not exceeded throughout the flight and to ensure the airworthiness of the dual front seat installation, accomplish the following:

Amend the aircraft flight manual (AFM) and introduce Ntech Dual Front Seat Flight Manual Supplement FMS 25.20.05 revision 4, dated 14 February 2020, or later approved revision, into the AFM.

Amend the aircraft maintenance programme and introduce Ntech Dual Front Seat Instructions for Continued Airworthiness ICA MB 25.20.05 revision 1, dated 14 February 2020, or later approved revision, into the aircraft maintenance programme.

Accomplish an inspection of the dual front seat installation per the instructions in ICA MB 25.20.05, unless previously accomplished within the last 1200 hours TIS, or 1200 cycles, or 48 months, whichever is the sooner since installation of modification MB 25.20.05 on the aircraft. Install a placard per FMS 25.20.05 on the left side of the

dual front seat installation in clear view of boarding passengers and flight crew, unless previously accomplished.

Note: FMS 25.20.05 revision 4, dated 14 February 2020, or later CAA approved revision and ICA MB 25.20.05 revision 1, dated 14 February 2020, or later approved revision can be obtained from:

NTech Limited
Ardmore Airport
PDC 14, Papakura, Auckland 2244
Tel: +64 9 296 1950
Fax: +64 9 296 1952
Email: info@ntech.co.nz

Compliance: At the next maintenance inspection, or the next review of airworthiness, or the next annual inspection, whichever occurs first.

Effective Date: 27 February 2020

2020-0064 Emergency Flotation System – Inspection

Applicability: AS 350 B, AS 350 B1, AS 350 B2, AS 350 BA, AS 350 BB, AS 350 B3, AS 350 D helicopters, all S/N.

Effective Date: 2 April 2020

2020-0175 Cancelled by EASA on 13 September 2021

Effective Date: 30 September 2021

2020-0186 Cancelled – EASA AD 2021-0099 refers

Effective Date: 29 April 2021

2020-0217-E Cancelled – EASA AD 2021-0023 refers

Effective Date: 2 February 2021

2020-0224R1 Tail Rotor Blades – Inspection

Applicability: AS 350 B, AS 350 BA, AS 350 BB, AS 350 B1, AS350 B2 and AS 350 D helicopters, all S/N.

Note 1: Initial tail rotor blade leading edge protection shield inspection: An initial inspection per requirements (1) and (2) of EASA AD 2020-0224 original issue, or revision 1, must be accomplished by an aircraft maintenance engineer.

Note 2: The visual inspection before every flight per requirement (1) of EASA AD 2020-0224R1, may be accomplished by adding the inspection requirement to the helicopter tech log. The visual inspection may be performed and certified under the provision in Part 43 Appendix A.1 (7) by the holder of a current pilot licence, if that person is rated on the aircraft, appropriately trained, and authorised (Part 43, Subpart B refers), and the maintenance is recorded and certified as required by Part 43.

If any defects are found in the tail rotor blades during the repetitive visual inspections, then an aircraft maintenance engineer must inspect the tail rotor hub body and accomplish the corrective actions per EASA AD 2020-0224R1, before further flight.

Effective Date: EASA AD 2020-0224-E - 20 October 2020
EASA AD 2020-0224R1 - 26 November 2020

2021-0023 Cyclic Stick Grip UP / Down Hoist Control Switch – Modification

Applicability: AS 350 B, AS 350 BA, AS 350 B1, AS 350 B2 and AS 350 D helicopters, all S/N, except those helicopters embodied with Airbus Helicopters modification MC20096.

Effective Date: 2 February 2021

- 2021-0048** **Cancelled – EASA AD 2023-0064 refers**
Effective Date: 3 April 2023
- 2021-0099** **Cancelled – EASA AD 2023-0075 refers**
Effective Date: 14 April 2023
- 2021-0123-E** **Tail Rotor Load Compensator – Inspection**
Applicability: AS 350 B, AS 350 B2, AS 350 B3 and AS 350 BA helicopters, S/N 1241, 1525, 1601, 1708, 1825, 1910, 1973, 2056, 2072, 2361, 2394, 3170, 3223, 3479, 3789, 9005, 9010 and 9035.
Effective Date: 11 May 2021
- 2021-0168** **Cancelled – EASA AD 2024-0018 refers**
Effective Date: 25 January 2024
- 2021-0194R1** **Cancelled – EASA AD 2024-0133 refers**
Effective Date: 25 July 2024
- 2021-0195** **Engine Digital ECU Emergency Procedure – AFM Amendment**
Applicability: AS 350 B3 helicopters, all S/N fitted with an ARRIEL 2D engine.
Effective Date: 3 September 2021
- 2021-0282R1 (Correction)** **Tail Rotor Head Pitch Change Unit Bearing Spacer - Inspection**
Applicability: AS 350 B, AS 350 BA, AS 350 BB, AS 350 B1, AS 350 B2, AS 350 B3 and AS 350 D helicopters, all S/N.
Effective Date: EASA AD 2021-0282 – 31 December 2021
 EASA AD 2021-0282R1 – 25 July 2024
 EASA AD 2021-0282R1 (Correction) – 30 January 2025
- 2022-0051** **(Correction) Rear Structure Junction Frame Reinforcement Angles - Inspection**
Applicability: AS 350 B, BA, BB, B1, B2, B3 and D helicopters, all S/N fitted with an affected part as defined in EASA AD 2022-0051, except helicopters embodied with Airbus Helicopters (AH) modification (MOD) 073232 in production, or helicopters embodied with AH AS350 Service Bulletin (SB) No. 53.00.58 in service.
Note: EASA AD 2022-0051 retains the requirements in superseded EASA AD 2014-0076R3, and requires repetitive inspections for additional helicopters.
 EASA AD 2022-0051 (Correction) is re-issued to correct typos in the referenced AD numbers in the Reason section of the AD.
Effective Date: EASA AD 2022-0051 - 5 April 2022
 EASA AD 2022-0051 (Correction) - 30 June 2022
- 2022-0077-E** **Flight Control Flexball Cables - Replacement**
Applicability: AS 350 B, AS 350 B1, AS 350 B2, AS 350 B3, AS 350 BA, AS 350 BB and AS 350 D helicopters, all S/N.
Effective Date: 2 May 2022
- 2022-0128** **Main Gearbox Bracket Bolts - Inspection**
Applicability: AS 350 B, AS 350 D, AS 350 B1, AS 350 B2, AS 350 BA, AS 350 BB and AS 350 B3 helicopters, all S/N.
Effective Date: 28 July 2022
- 2022-0246** **Main Rotor Blades - Inspection**
Applicability: AS 350 B, AS 350 B1, AS 350 B2, AS 350 BA, AS 350 BB and AS 350 D helicopters, all S/N.
Effective Date: 26 December 2022

2023-0044 Main Gearbox Planet Gear - Inspection

Applicability: AS 350 B, AS 350 D, AS 350 B1, AS 350 B2, AS 350 BA, AS 350 BB and AS 350 B3 helicopters, all S/N.

Effective Date: 30 March 2023

2023-0064 Main Rotor Pitch Rod Upper Links - Inspection

Applicability: AS 350 B, AS 350 BA, AS 350 BB, AS 350 B1, AS 350 B2, AS 350 B3 and AS 350 D helicopters, all S/N.

Note: The repetitive visual inspections required at intervals not to exceed 10 hours TIS per requirement (2) of EASA AD 2023-0064 may be accomplished by adding the inspection requirement to the helicopter tech log. The visual inspection may be performed and certified under the provision in Part 43 Appendix A.1 (7) by the holder of a current pilot licence, if that person is rated on the aircraft, appropriately trained, and authorised (Part 43, Subpart B refers), and the maintenance is recorded and certified as required by Part 43.

If the markings on one, or both sides of a main rotor pitch rod upper link are found misaligned during the repetitive visual inspections, then an aircraft maintenance engineer must accomplish the corrective actions per requirement (3) of EASA AD 2023-0064 before further flight.

Effective Date: 3 April 2023

2023-0075 Cancelled – EASA AD 2023-0089 refers

Effective Date: 18 May 2023

2023-0089 Cancelled – EASA AD 2024-0139 refers

Effective Date: 26 July 2024

2023-0107 (Correction) Cargo Swing Frame - Inspection

Applicability: AS 350 B2 and AS 350 B3 helicopters fitted with an onboard cargo hook P/N 704A41811035 and with any P/N cargo swing frame.

Effective Date: 29 June 2023

2023-0127 Main Gearbox Engine Coupling - Inspection

Applicability: AS 350 B, AS 350 B1, AS 350 B2, AS 350 BA, AS 350 BB, AS 350 B3 helicopters, all S/N with a date of manufacture before 15 May 2023; and

AS 350 D helicopters, all S/N with a date of manufacture before 15 May 2023, except helicopters fitted with a Lycoming engine.

Effective Date: 11 July 2023

2023-0131 Sliding Doors - Inspection

Applicability: AS 350 B, AS 350 D, AS 350 BA, AS 350 BB, AS 350 B1, AS 350 B2 and AS 350 B3 helicopters, all S/N, fitted with a left-hand (LH) and/or a right-hand (RH) sliding door.

Effective Date: 27 July 2023

2023-0133 Cancelled – EASA AD 2023-0187 refers

Effective Date: 30 November 2023

*** 2023-0187R1 Microswitches - Inspection**

Applicability: AS 350 B3 helicopters, all S/N.

Effective Date: EASA AD 2023-0187 - 30 November 2023
EASA AD 2023-0187R1 - 27 March 2025

2024-0018 Indicating / Recording Systems Control Unit – Inspection

Applicability: AS 350 B2 and AS 350 B3 helicopters, all S/N.

Effective Date: 25 January 2024

2024-0133 Airworthiness Limitations Section - Amendment

Applicability: AS 350 B, AS 350 BA, AS 350 BB, AS 350 B1, AS 350 B2, AS 350 B3, AS 350 D helicopters, all S/N.

Effective Date: 25 July 2024

2024-0139 Vertical Fin - Inspection

Applicability: AS 350 B3 helicopters, all S/N except those helicopters embodied with modification (MOD) 073148 in production.

Note: The repetitive visual inspections required at intervals not to exceed 10 hours TIS per requirement (6) of EASA AD 2024-0139 may be accomplished by adding the inspection requirement to the helicopter tech log.

The visual inspection may be performed and certified under the provision in Part 43 Appendix A.1 (7) by the holder of a current pilot licence, if that person is rated on the aircraft, appropriately trained, and authorised (Part 43, Subpart B refers), and the maintenance is recorded and certified as required by Part 43.

If any evidence of cracks or defects are detected in the right-hand side of the vertical fin spar, then an aircraft maintenance engineer must accomplish an inspection per requirement (6) of EASA AD 2024-0139, before further flight.

Effective Date: 26 July 2024

2025-0025 Emergency Release Control of Cargo Swing Installation – Inspection

Applicability: AS 350 B2 and AS 350 B3 helicopters, all S/N fitted with an Onboard 3500LB cargo system P/N 704A41811035 (manufacturer reference 528-023-51).

Effective Date: 6 February 2025

2025-0036 Cargo Hook Assembly – Inspection

Applicability: AS 350 B, AS 350 BA, AS 350 BB, AS 350 B1, AS 350 B2, AS 350 B3 and AS 350 D helicopters, all S/N.

Effective Date: 27 February 2025