

1998, Issue 4

VECTOR

Pointing to Safer Aviation



**Flying a Taildragger
A Landing Forced Upon You
Uncontrolled IFR**

Editor: Cliff Jenks

Assistant Editors: Pam Collings, Barnaby Hill, Clare Jeeves

Design & Typesetting: Siren Communications

Published by: Civil Aviation Authority of New Zealand, P O Box 31-441, Lower Hutt, NEW ZEALAND.

Telephone +64-4-560 9400

Fax +64-4-569 2024

Editor Internet: JenksC@caa.govt.nz.

Normally published eight times a year.

Publication Content

The views expressed in *Vector* are those of the Editor or the named contributor. They are intended to stimulate discussion and do not necessarily reflect the policy of the Civil Aviation Authority. Nothing in *Vector* is to be taken as overriding any New Zealand Civil Aviation legislation, or any instructions issued or endorsed by the Civil Aviation Authority of New Zealand.

Reader comments and contributions are welcome and will normally be published, but the Editor reserves the right to edit or abridge them, and not to publish those that are judged not to contribute constructively towards safer aviation. Reader contributions and correspondence regarding the content of *Vector* should be addressed to: Vector Editor, PO Box 31-441, Lower Hutt.

Distribution

Vector is distributed automatically to New Zealand Flight Crew and Aircraft Maintenance Engineer licence holders, to most organisations holding an Aviation Document, and to certain other persons and organisations interested in promoting safer aviation. *Vector* articles also appear on CAA's website at <http://www.caa.govt.nz/>

Vector is available on subscription only from Publishing Solutions Ltd, PO Box 983, Wellington, freephone 0800 800 359, phone +64-4-471 0582, fax +64-4-471 0717.

Change of Address

Readers receiving *Vector* free of charge should notify the Civil Aviation Authority (Safety Certification Clerk) of any change of address; quoting your CAA Client Number (or licence number) will assist in administration. Paying subscribers should notify Publishing Solutions Ltd.

Copyright

Reproduction in whole or in part of any item in *Vector*, other than material shown to be from other sources or named authors, is freely permitted, providing that it is intended solely for the purpose of promoting safer aviation, and providing that acknowledgment is given to *Vector*.

Next Issue

Our publications are next scheduled to be in your letterbox by late July 1998.

ISSN 1173-9614

1998, ISSUE 4
Distributed June 1998



Page 4-6 Static in the Fuel?

What are the most effective methods of preventing static build-up during refuelling?



Page 7-12 A Landing Forced Upon You

What should you consider if you had the choice between a forced landing and a ditching?

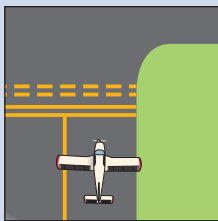

Page 13-14 Aerodrome Markings – A Guide

Are you thoroughly familiar with standard ground markings, as well as the layout of the manoeuvring area and ground movement procedures?



Page 15-16 Avoid That Wire Strike!

There have been 67 wirestrike accidents in New Zealand since 1978 in which 33 lives have been lost.



Page 17-19 Flying a Taildragger

A common mistake made by new taildragger pilots is raising the tail too high during takeoff.



Page 20 Mind Your Ps and Qs

The history of Q-Codes and their use today.



Page 21-23 Uncontrolled IFR

Operating in uncontrolled airspace increases your workload and stress, because now you have to be both pilot and controller.

Also Featuring:

Page 6	Annual VFG and Chart Editions
Page 16	GAPs in Your Knowledge
Page 16	Improved National Briefing Office Services
Page 20	Seat Twist Follow-Up

Front Cover Photograph

Piper PA18-150 Super Cub flying over the Canterbury Plains near Mount Hutt, courtesy of Tim Scotter.



Safety Seminars

Planning is well under way for this year's series of safety seminars. The theme this year revolves around maintenance requirements and responsibilities and is applicable to general aviation pilots, operators, owners and engineers.

The focus is not upon the specifics of how to do particular maintenance but is upon the critical framework of rules, requirements and responsibilities that exist between pilots, aircraft operators, owners and engineers in order to achieve compliance and high safety standards.

Achieving a high standard of maintenance is a function of good plant, good planning and good decisions. The seminar looks at the ingredients to assist this and highlights the relationships that exist between engineer, owner, operator and pilot to achieve serviceability and safety. The roles and responsibilities of all the participants are explored.

If you fly, operate or own an aircraft, then this seminar is pertinent to you.

The seminars will be presented by Owen Walker, CAA Field Safety Adviser (Engineer), and he will be assisted by industry engineers.

While we will continue with the separate Heli-Kiwi and Aero-Kiwi titles, we emphasise again that **you can attend either type of seminar** – the topic is universal, and we will incorporate both helicopter and fixed-wing examples in each seminar.

Aero-Kiwi seminars will be scheduled later in the year. First up are 10 Heli-Kiwi seminars scheduled in July and August as follows:

Thurs, 16 Jul, 7.30 pm – 10.00 pm.

Heli-Kiwi Seminar. **Kerikeri**, Quantum at Woodlands 126 Kerikeri Road.

Mon, 27 Jul, 7.30 pm – 10.00 pm.

Heli-Kiwi Seminar. **Ardmore** Aerodrome, at Auckland Aero Club.

Tue, 28 Jul, 7.30 pm – 10.00 pm.

Heli-Kiwi Seminar. **Taupo** Aerodrome, at Taupo Aero Club.

Wed, 29 Jul, 7.30 pm – 10.00 pm.

Heli-Kiwi Seminar. **Paraparaumu** Aerodrome, at Associated Aviation.

Tue, 4 Aug, 7.30 pm – 10.00 pm.

Heli-Kiwi Seminar. **Gisborne** Aerodrome, at Gisborne Pilots' Association.

Sun, 9 Aug, 2.00 pm – 4.30 pm.

Heli-Kiwi Seminar. **Kaikoura** Aerodrome, at Terminal Building.

Mon, 10 Aug, 7.30 pm – 10.00 pm.

Heli-Kiwi Seminar. **Twizel**, at Mackenzie Country Inn.

Tue, 11 Aug, 7.30 pm – 10.00 pm.

Heli-Kiwi Seminar. **Mandeville** Aerodrome, The Moth Restaurant and Bar.

Wed, 12 Aug, 7.30 pm – 10.00 pm.

Heli-Kiwi Seminar. **Queenstown**, at Sherwood Manor Hotel.

Thurs, 13 Aug, 7.30 pm – 10.00 pm.

Heli-Kiwi Seminar. **Franz Josef**, at Franz Josef Glacier Hotel.

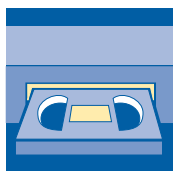

Videos

Here is a consolidated list of safety videos made available by CAA. Note the instructions on how to borrow or purchase (ie, don't ring the editors.)

Civil Aviation Authority of New Zealand

No	Title	Length	Year released
1	Weight and Balance	15 min	1987
2	ELBA	15 min	1987
3	Wirestrike	15 min	1987
5	The Human Factor	25 min	1989
6	Single-pilot IFR	15 min	1989
7	Radar and the Pilot	20 min	1990
8	Fuel in Focus	35 min	1991
9	Fuel Management	35 min	1991
10	Passenger Briefing	20 min	1992
11	Apron Safety	15 min	1992
12	Airspace and the VFR Pilot	45 min	1992
13	Mark 1 Eyeball	24 min	1993
14	Collision Avoidance	21 min	1993
15	On the Ground	21 min	1994
16	Mind that Prop/Rotor!	11 min	1994
17	Fit to Fly?	23 min	1995
18	Drugs and Flying	14 min	1995
19	Fatal Impressions	5 min	1995
20	Decisions, Decisions	30 min	1996
21	To the Rescue	24 min	1996
22	It's Alright if You Know What You Are Doing – Mountain Flying	32 min	1997
23	Momentum and Drag	21 min	1998

Miscellaneous individual titles

Working With Helicopters	8 min	1996*
--------------------------	-------	-------

Civil Aviation Authority, Australia

The Gentle Touch (Making a safe approach and landing)	27 min
Keep it Going (Airworthiness and maintenance)	24 min
Going Too Far (VFR weather decisions)	26 min
Going Ag – Grow (Agricultural operations)	19 min
Going Down (Handling emergencies)	30 min

The videos are VHS format and may be freely copied, but for best quality obtain professional copies from the master tapes — see "To Purchase" below.

The New Zealand tapes are produced on a limited budget, the first 11 titles using Low-band equipment. Quality improves in later titles. While the technical quality of the videos may not be up to the standard of commercial programmes, the value lies in the safety messages.

To Borrow: The New Zealand tapes may be borrowed, free of charge, as single copies or in multi-title volumes (Vol A contains titles 1 to 8, Vol B titles 9 to 14, Vol D titles 15 onwards). The Australian programmes are on a multi-title volume (Vol C). Contact CAA Librarian by fax (0-4-569 2024), phone (0-4-560 9400) or letter (Civil Aviation Authority, PO Box 31-441, Lower Hutt, Attention Librarian). **There is a high demand for the videos, so please return a borrowed video no later than one week after receiving it.**

To Purchase: Obtain direct from Dove Video, PO Box 7413, Sydenham, Christchurch. Enclose: **\$10 for each title** ordered; plus **\$10 for each tape** and box (maximum of 3 hours per tape); plus a **\$5 handling fee** for each order. All prices include GST, packaging and domestic postage. Make cheques payable to "Dove Video".

Static in the Fuel?

The following article has been contributed by Jane Lenting, Electrical Engineer for BP Oil New Zealand Ltd. It investigates the dangers associated with static electricity build-up during aircraft refuelling. Jane describes what precautions we can take, before refuelling our aircraft, to reduce the risks of a potentially catastrophic fire or explosion caused by a static spark.

What is Static?

Static is experienced when materials, the environment, and our activities conspire to allow positively and negatively charged molecules to accumulate on different surfaces. If we then separate these surfaces, or move them relative to each other, a voltage difference will be set up.

Common examples of static build-up result from layers of clothing moving relative to one another, and also from contact with objects like car doors. There is generally no observable effect until the surfaces are separated – clothing will start crackling only when garments are removed, for example. Static can be generated when we separate our clothing surface from a car seat, which then leaves the car charged. We then provide a path for this accumulated charge to earth by touching the car door while standing on the ground and receive a static shock.

Static electricity tends to be associated with very high voltages – often over 10,000 volts – but only tiny amounts of current. Electrostatic fields temporarily set up with clothing and cars do not have sufficient stored energy to place us in any physical danger.

Static and Aviation Fuel – A Bad Mix?

There is always the risk that static electricity might ignite a flammable material, such as Avgas, causing a fire or explosion. Although such stored static energy is too low to harm us directly, the same amount of electrical energy, when dissipated in a spark, is more than enough to ignite fuel vapour.

A flammable air/vapour mix of Avgas requires only 200 micro-joules of spark energy to initiate an explosion. This could be provided by a pulse of electrical energy consisting of a fraction of an amp at 50 volts. Note that the minimum spark

energy for ignition of Jet A-1 is similar to that of Avgas.

In New Zealand, Jet A-1 is generally less hazardous than Avgas because of the lower environmental temperatures that we experience relative to many other



countries. The risk of Jet A-1 reaching flash-point and igniting is slightly reduced because of this. Local temperatures need to be above 38 degrees Celsius before the vapour above the liquid fuel surface forms a flammable air/vapour mix that will sustain an explosion. **Jet A-1 still needs to be treated with respect**, however, in terms of avoiding any contact with an ignition source. Why? Because tarmac temperatures can rise above 38 degrees Celsius at some aerodrome locations around New Zealand.

Why Does Static Build Up In Fuel?

Petroleum fuels are generally poor conductors of electricity. This low conductivity allows an accumulation of charge – and fuel itself does not instantly dissipate any charge that has built up.

Aviation fuels are handled in a way that makes accumulation and separation of charge more likely. Two examples of this are the use of very fine filters during product transfer, and the need for fast refuelling of commercial aircraft.

Although static electricity is of concern throughout the petroleum industry, the handling of aviation fuels presents special risks that can be reduced by fuel specification, equipment design, and operating procedures – these are discussed later in the article.

What Is Happening On a Molecular Level?

Hydrocarbons, such as aviation fuels, are almost entirely made up of molecules which are not 'ionised' – that is, they are neither positively nor negatively charged. However, there are some molecules present which are ionised – although the proportion is very small. In most situations these ionised molecules are undetectable.

These positively and negatively charged molecules will stay spread throughout the fuel, except where there is an interface with a different material, such as metal or plastic. In this situation, the charged molecules will separate and accumulate on different surfaces. The positively charged molecules will accumulate in the fuel and the negatively charged molecules on a surface – such as the inside of a metal pipe. This is not a problem, providing the metal and the molecules of fuel stay in contact.

If they separate, however (such as during refuelling), or move relative to each other, then the positively charged molecules are carried along with the fuel. This effectively means that there is an electric current flowing in the pipe. The negatively charged molecules will remain on the pipe, unless that particular part of the pipe is bonded to earth, in which case it will be neutralised through a small current flow to ground. Thus a voltage difference is set up. As fuel itself is not a good conductor, this voltage difference remains, and it increases as the separation (ie, flow) increases.

Photo courtesy of BP Oil New Zealand Ltd.

Over a period of time these charges migrate and recombine with oppositely charged molecules – a process known as ‘charge relaxation’. Eventually the voltage difference decays away to near zero, in a period known as the ‘relaxation time’ – which can be anything from a fraction of a second to a period of minutes. This means that the possibility of a static spark within a tank is always a short-term risk, following activity which has allowed the electrostatic field to develop. Relaxation times for Avgas in light aircraft involved in refuelling will be very short – just a few seconds or less.

Identifying Static Hazards

If splashing or spraying occurs during the refuelling process (most likely during top-loading of a tank) a charged mist or foam can be produced, which results in a voltage difference between different locations within the same tank. Such a potential difference can be dissipated in a static spark – in the worst case. Other processes, such as steam cleaning a tank with flammable vapours still present, also produce charged mists and are therefore hazardous.

Another area of concern is the speed of fuel transfer though a refuelling hose, where higher speeds result in greater charge separation and more fuel splashing.

“The most effective method of preventing static build-up during refuelling is to bond the aircraft.”

The use of fine filters during refuelling is unavoidable within the aviation industry. The effect of having a fine filter in a fuel line is to bring more fuel molecules in contact with the dissimilar material of the filter, resulting in higher charge separation. Fuel flow in a line with a very fine filter will typically generate 10 to 100 times the charge separation of the same line without a filter.

Preventing Static Hazards

Ignition caused by static discharge is infrequent and preventable. Between 1953 and 1971, there were 35 aircraft accidents involving fire and explosions attributable to static discharge. Since the mid 1970s, reports of such incidents have

been greatly reduced by the use of some important static mitigation designs and procedures that have become widely used.

Aircraft Bonding

The most effective method of preventing static build-up during refuelling is to bond the aircraft. By bonding we mean connecting the metal structure of the aircraft to earth – via a cable or other conducting path. Bonding itself will not prevent the accumulation and separation of charge (and therefore the development of a voltage difference) between the fuel and the surface it comes in to contact with during refuelling. However, by the time refuelling has stopped, and the relaxation time elapsed, the bonding connection will have safely dissipated the charge that has accumulated on the inside surface of the refuelling hose and nozzle,

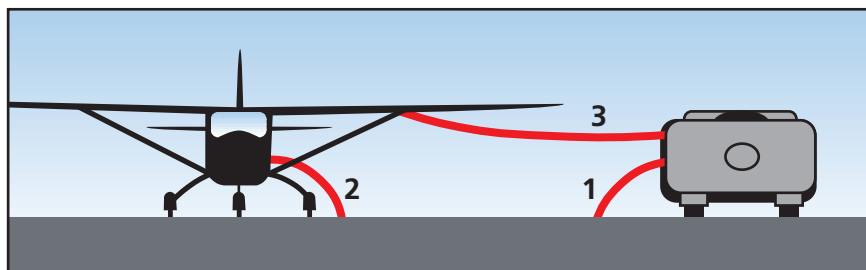

The diagram shows the correct way in which to bond an aircraft during refuelling to ensure that a static potential does not build up.

as well as any charge which has accumulated on the aircraft during flight. A failure to connect the bonding cable, and to leave it connected until refuelling is complete, may mean that the conditions exist for a spark to be generated between the refuelling nozzle and the aircraft tank fill point. The area near the entrance to the fill point is likely to contain fuel vapour within the flammable range, and if it does, this spark will have a good chance of causing ignition.

Bonding of the aircraft before refuelling is accepted procedure for all types of aircraft. It is up to the individual pilot (or the ground refueller) to appreciate the reasons for this procedure and to apply it consistently with every refuelling.

Anti-Static Additives

The introduction of additives which increase the conductivity of aviation fuels has been one of the most significant developments historically. These additives do not prevent charge separation – in fact they increase it. However, they reduce the relaxation time by changing the fuel conductivity, and they almost eliminate the possibility of this charge

separation being dissipated as a spark within a tank.

Without the anti-static additive Stadis 450, Jet A-1 would have a greater static risk than Avgas at ambient temperatures above 38 degrees Celsius. This is because the conductivity of Jet A-1 without the additive is lower than that of Avgas.

Fuel Velocity During Transfer

Oil companies use industry guidelines for maximum fuel velocities that relate to the pipe diameter and the type of fuel. Typical values might be around one metre per second until the inlet point is covered by fuel, and up to seven metres per second for the remaining refuelling operation. Lower fuel velocities also mean less foaming and splashing, thereby reducing the risks of producing a charged mist.

Filter Design

Experience has shown us that unfavourable filter design can result in increasing charge separation. It is wise to check that your aircraft refuelling system has the approved fuel filters fitted in order to reduce the chances of static build-up.



Ensure that your aircraft refuelling system has the approved fuel filters fitted so that the chances of static build-up are reduced.

Summary

It is worth making the effort to ensure that your aircraft is correctly bonded while refuelling. It takes only the smallest of sparks to ignite aviation fuel during the refuelling process, causing a fire or explosion. Hot and dry atmospheric conditions pose the greatest risks and mean that extra care is needed – especially on a northwest day for example.

Vector Comment

Other safety tips that *Vector* recommends you adopt when you are next involved in refuelling an aircraft include:

- Make sure that the bonding cable is in good condition and is securely attached to a clean metal surface that will conduct current easily.
- Avoid using any electrical devices around the aircraft while refuelling is occurring – the risk of dropping a portable phone or radio resulting in a spark is not worth taking.
- Be careful about introducing other sources of static while refuelling, such as may be present on clothing. Avoid wearing items like nylon jackets, and certainly do not remove them while refuelling, as this may result in a static charge build-up.
- Ensure that you know where the fuel pump emergency cut-off switch and fire extinguisher are.
- Release the aircraft brakes (this particularly applies to light aircraft) so that you are able to push the aircraft away from the refuelling source if a fire does occur. ■

Annual VFG & Chart Editions

The following notification has been prepared by Aviation Publishing, who are responsible for the production and distribution of the VFG, charts, and other New Zealand AIP documents.

From July 1998 the VFG, VTC charts, 1:500 000 charts, and enroute charts will be published annually – making it easier and cheaper to stay up to date.

This was decided after consultation with Aviation Publishing customers and the CAA (who are responsible for the development and design of airspace). Customer consultation was achieved via an Aviation Publishing customer survey and roadshow. Cost and frequency were found to be important issues for many subscribers.

For VFG subscribers, this will mean a reduction in annual subscription costs from \$83 to \$75. This subscription fee will cover the production and distribution of the VFG, AIP Supplements, change notices and AICs. These additional products will continue to be sent out every four weeks throughout the year as per normal.

While the price of the VFG has been reduced, the price of charts will increase slightly. In the past the costs of producing charts were offset by subscription funds held in advance. Now, with only one edition each year, this is no longer possible. Customers will still notice a considerable cost saving, as they now only have to purchase charts once a year.



The extent of the savings passed on to you will depend on what products you purchase. The following comparison is given for a customer purchasing the VFG, VTCs (both AA/OH and WN/CH) and two 1:500 000 charts.

For the combination of products tabled above, the old price was \$189 per year – it will now be \$151 meaning **a saving of \$38 per year.**

The change to annual editions for the VFG and charts will occur on 6 July 1998, creating a standardised subscription period from July to June of each year. This ensures no inconvenience to the majority of customers who already have current VFG and chart subscriptions over this period. Customers whose subscriptions expire with what would have been the December 1998 edition of the VFG, can pay to continue their subscription through until July 1999 (and continue to receive Change Notices, AIP Supplement and AICs).

The new subscription period also means products that become effective in July will remain current throughout the busiest general aviation period – daylight saving months. This also allows changes to be made to the VFG and charts at what is traditionally a quieter time of the year.

Product	Old price	New price
VFG	\$83.00 (2 editions)	\$75.00
Auckland/Ohakea VTC	\$25.00 (2 editions)	\$18.00
Wellington/Christchurch VTC	\$25.00 (2 editions)	\$18.00
1:500 000 charts (per sheet)	\$28.00 (2 editions)	\$20.00

A Landing Forced Upon You

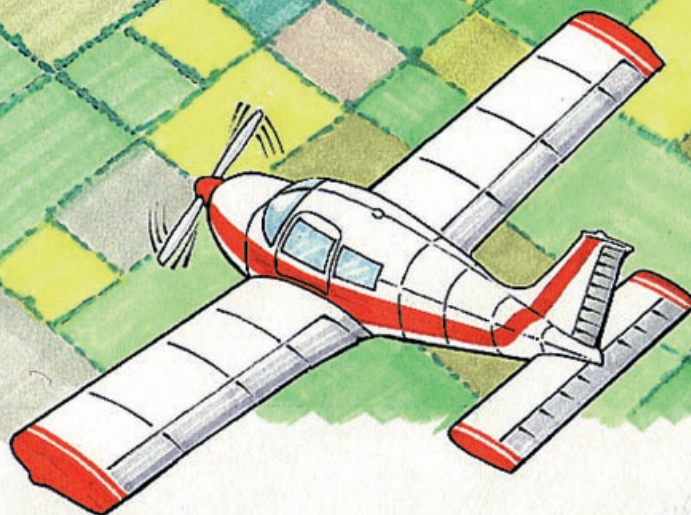

Keeping current with forced-landing techniques is an extremely important aspect of safety in general aviation. It helps to ensure that we give ourselves the best possible chance of walking away, uninjured, from an aircraft after an engine failure. The following article provides a revision of the basic techniques for a forced landing without power for pilots of light single-engine aircraft and then goes on to consider engine failure options when over less hospitable types of terrain.

Successfully handling an engine failure, or partial power loss, requires decisive pilot action combined with well rehearsed forced-landing cockpit drills. The ability to respond quickly by selecting a suitable landing site, and then conducting the forced-landing drills, are absolutely essential survival skills.

The first section of this article is dedicated to basic forced-landing-without-power (FLWOP) techniques. It assumes an engine failure in a light single-engine aircraft from above 2000 feet over an area that offers reasonable forced-landing possibilities. Since we know that this type of scenario is not always reality, the last section of the article deals with the options associated with more difficult types of terrain. Refer to *Vector* 1998, Issue 3 for information on engine failures under 1000 feet agl.

Immediate Actions

Prioritising your time after an engine failure will help you to accomplish as many of the critical drills as are possible. The 'immediate actions' are the first part of the FLWOP sequence. They help ensure that the aircraft is trimmed for its best glide speed and that the engine is given sufficient time to respond to carburettor (or induction system) ice and fuel starvation checks. The immediate actions are summarised below.

Excess Speed to Height

At the first sign of engine trouble convert any excess airspeed, above the best glide speed, to valuable height. (In many light aircraft with relatively modest cruise speeds this simply means preventing unnecessary loss of height by holding the nose up until glide speed is reached.) Care must be taken not to reduce airspeed too much, thereby bringing the aircraft close to the stall.

Trim for best glide speed and apply the appropriate rudder to remain in balance. Note that, although drag can be reduced by stopping the propeller, it is not recommended practice as it requires



bringing the aircraft close to the stall. It is also doubtful whether the reduction in drag will compensate for the height lost in the subsequent recovery to the best glide speed. In addition to this it may also cause pilot distraction.

When the aircraft propeller is fitted with a constant-speed unit, the selection of coarse pitch will reduce drag and improve gliding performance.

Carburettor Ice and Fuel Checks

Carburettor heat or alternate air should be applied as soon as possible. In the case of normally aspirated engines, this will allow the remaining heat from the engine to be utilised in melting any carburettor ice that may have formed. The electric fuel pump should also be turned ON, fuel tanks changed (if possible), and the throttle closed.

Determining Wind Direction

The first criterion for selecting a landing area must be the wind direction, particularly if the wind is strong. Knowing the wind direction will allow you to narrow down the possible landing sites. Wind direction is an extremely important piece of information, as an into-wind landing ensures the lowest possible landing speed. Landing with a tailwind could be fatal – it not only reduces your chances of achieving your planned aiming point, but also it could mean a much higher impact speed in the case of an overrun. Note that it is generally a good idea to keep track of the wind direction **at all times** while flying.

Wind direction and speed can be determined from many cues:

Continued over...

- **Smoke.** If there is any within your vicinity, it will provide the best indication of the surface wind speed and direction.
- **Dust.** Like smoke, this provides a very good indication of the surface wind. Watch for vehicles moving along shingle roads, tractors working paddocks, fertiliser spreading and even dust from river beds.
- **Tree or crop movement.** Movement of large trees and wind ripples moving across the top of crops can give a good indication of surface wind direction. Movement in the tops of large trees, in moderate to strong winds, can be quite pronounced – even from altitude.
- **Wind lanes or wind shadow.** In moderate to strong winds, water movement or waves can give an indication of surface wind direction, especially over large bodies of water. On the other hand, wind shadow is the result of water at the upwind end of a body of water being protected by the shoreline, creating an area of calm. This effect is most noticeable in light wind conditions on small lakes or ponds.
- **Cloud shadow.** The movement of cloud shadow over the ground gives the wind direction at altitude. Care should be taken to ensure that there is not a marked difference between this indication and what is happening on the ground.
- **Local knowledge.** If you have local knowledge of the weather conditions relating to the area you are operating in, then make full use of such information. The windsock indication and known takeoff direction at your aerodrome of departure (if nearby) may give an indication of wind direction.
- **Aircraft drift.** By looking at any drift angle that you might be experiencing you can gain a limited indication of the wind direction at the aircraft's present altitude – but not at surface level. Using drift angle to determine wind direction works best in strong wind conditions.
- **Weather reports.** If operating in close proximity to an aerodrome about which you have recently heard weather information such as an ATIS, TAF or METAR, then this could be used to help give you an approximate idea of the surface wind. This information should be used only to

supplement that received by the methods above – methods which should always be used anyway.

Selecting a Landing Site

Here we deal with the selection of a landing site when an engine failure occurs over reasonably flat types of terrain at approximately 2500 feet agl. This is similar to that which many of us are accustomed to during forced-landing practice.

The area of likely landing sites **must be within easy gliding distance** before any other selection criteria are applied. The aircraft should be turned in the general direction of the area so as not to drift away and lose valuable height. Landing site selection can then be best achieved by using the mnemonic such as 'the seven Ss' which stand for size, shape, slope, surface, surroundings, stock, and sun. They are listed in an order of importance so as to help you narrow down the options:

Size. Look for the longest possible landing site that faces into wind. Get to know what sort of distance your particular aircraft is capable of landing in (consult your aircraft flight manual and your instructor).

“... it is generally a good idea to keep track of the wind direction at all times while flying.”

Shape. Do not limit your selection to sites that resemble a rectangular runway. The perfect shape for a FLWOP is in fact a circle, as it allows approaches to be made from many different directions over obstacles and ensures a landing into wind. Bear in mind that it may be beneficial to land diagonally across landing sites that are rectangular, as this provides the longest possible landing distance.

Slope. An uphill slope for landing is preferred, so as to reduce the landing roll. A downhill slope should be avoided unless the wind strength negates the disadvantages of landing on a very gradual downhill slope. A downhill landing should be attempted only when there is a **strong headwind** present and the gradient of the slope is **known to be slight**. It can be difficult to judge the gradient of a slope from altitude – rivers and creeks running downhill, however, may give you some clues.

Surface. A firm landing surface is preferred to prevent the aircraft from digging in, possibly causing it to flip over. As with determining slope, determining what kind of surface you are looking at has its problems. The colour and texture of the surface foliage can indicate how firm a potential landing site might be. The presence of surface water is always an indication that the site might be soft. A comparison of what each surface looks like in relation to a grass aerodrome runway can be useful.

Surroundings. Where possible, it is advisable to select a landing site that has a clear approach path at the into-wind end. The ideal approach should be void of tall trees, power lines and buildings that will prevent you from achieving an unimpeded profile to your landing site. It will also mean that undershooting your landing site is less likely to result in collision with a solid obstacle. Some consideration should be given to the presence of obstacles at the top end of the landing site, as a landing overrun could occur.

Stock. Try to avoid landing sites where stock are present. If, however, they are concentrated in one end of the paddock and are not tending to move around too much, then consider using the site – if there are no other more suitable alternatives.

Sun. This is normally a problem only twice a day, sunrise and sunset. Under these conditions an approach in the direction of the sun may blind the pilot on final. Try to avoid this if possible

Note that if an opportunity exists to land towards nearby buildings, which might have a telephone and people to assist you, then take it. If your forced landing does result in injuries, then you know that medical help will hopefully be only a phone call away.

Planning Your Approach

Now that you have selected the most suitable landing site that is into wind, you must plan your approach to it. This is probably one of the most important phases of the FLWOP process. A well planned approach profile will put you into a position from which you can turn onto a base leg, at the correct height, and continue with a landing approach from which a successful outcome is likely. Note that the approach should be planned **from the ground up**. The following sequence is suggested for planning an approach to a landing site:

Aiming point. You must select an aiming point that is approximately one third of the way into the landing site. This gives you a constant point to aim for and helps ensure that you do not undershoot the landing site (see diagram).

Circuit direction. This should preferably be lefthand, so that the pilot in command may obtain the optimum view of the landing site – unless there is a specific reason to fly a righthand pattern. (Righthand pattern FLWOP practice is important, however, because some landing sites may offer no alternative.)

1000-foot AGL area. The 1000-foot area should be at 90 degrees to the landing site threshold and about three quarters of the normal circuit distance out. Arriving at the 1000-foot area will then allow you to position onto a base leg depending on the wind strength and

direction. The stronger the wind the earlier you will need to turn on to a square base leg (see diagram). Extending downwind in windy conditions would mean a very slow groundspeed on final approach, causing an undershoot. If you are unsure of what the various angles and perspectives from the 1000-foot area to the landing site look like, then it can be useful for an instructor to show you next time you take a dual flight.

1500-foot AGL area. The 1500-foot area is situated at the upwind end of the landing site and helps you to position yourself correctly at the start of the downwind leg. The 1500-foot area works on the assumption that you will lose around 500 feet in the downwind leg (depending on aircraft type) meaning that you should arrive at the 1000-foot area at the correct height (see diagram).

Assessing Your Approach

You must now try to make your approach fit these reference areas.

Estimate the elevation of the landing site above sea level. This is where keeping track of the ground elevation that you have been flying over comes in handy. Then, using your altimeter, work out how much height you will have to glide to achieve the 1500-foot area.

You can then make decisions, based on this information, as to whether to fly a direct line to the 1500-foot area or purposely manoeuvre to lose height. Constantly assessing how your approach profile is going is crucial. Cross-check your visual height judgement with your altimeter. Estimate the distance-to-run to achieve each reference point – and don't forget the effect wind will have on each segment of your approach pattern.

Continued over...



If too high relative to either the 1500-foot or 1000-foot areas, you **should not** commence an orbit to lose height. In turning your back on the chosen landing site, you may lose too much height and also lose sight of the landing site. Rather than orbit, it is better to make a series of S-turns (medium turns that will increase the rate of descent).

When faced with turbulent and gusty conditions, it may be necessary to increase your airspeed a little above the aircraft's best glide speed to provide a greater margin above the stall. The same technique should also be applied when trying to make headway to a landing site into a strong headwind – it provides better forward penetration to the landing site relative to the amount of height lost. If there is a considerable amount of sinking air around (such as during northwesterly wave conditions) then try and fly out of the 'sink' as fast as possible to more favourable conditions. Sinking air can rapidly erode the precious height you have and make judging your approach extremely difficult indeed.

Subsequent Actions

Once you have planned your approach to a landing site, and you feel that it is progressing well, then the next priority is to carry out the subsequent actions. You can do this knowing that you have a definite plan to achieve your landing site. It is very important to maintain **good situational awareness** relative to your chosen landing site while conducting any of the subsequent actions. You should **fly the aircraft first and foremost**, and then worry about completing the cockpit drills. Your pilot scan should be directed **outside the aircraft cockpit on a regular basis** so that small adjustments in heading can be made that ensure you are sticking to your planned approach.

Engine Trouble-Checking

Engine trouble-checking allows you the opportunity to assess what has caused your engine to lose power and to see if you can rectify the situation. There is obviously little point in continuing with a forced landing if you are simply suffering from fuel starvation in one tank, when there is plenty in the other, for

example. If there is any doubt about whether your engine will continue to run, then you should **stick with the forced-landing approach that you have planned**.

Trouble checks are based upon the mnemonic FMIIP priority system and should be learned so that they are absolutely automatic. Refer to *Vector*



1998, Issue 3 for details of engine trouble-checks – alternatively consult your instructor or pilot briefing notes.

Check your progress to the landing site and make any necessary adjustments.

Emergency Radio Call

If you have a radio, it is important to get a Mayday call out while squawking 7700 on your transponder before you lose too much altitude for these transmissions to be effective. Details of distress calls can be found on the back cover of the VFG. If time is limited, then at least transmit your present position and intentions to give authorities the best possible chance of finding you.

“... likely landing sites must be within easy gliding distance ...”

Once you have landed safely, remember to cancel any emergency radio call that you have made – aircraft owners or operators should also be contacted as well. This will save Search and Rescue costs.

Check your progress to your landing site and make any necessary adjustments – by now you may be nearing the 1500-foot area.

Passenger Briefing

A passenger briefing is of great value to calm your passengers down and to give them the confidence that you have the

situation well under control. It will not only remind them of what you told them during the preflight passenger briefing, but also enables you to stress **that you need to concentrate** on the rest of the forced-landing approach. This is really important as it is next to impossible to accurately fly an aircraft with hysterical passengers asking questions. Consult your instructor or pilot briefing notes for details of passenger briefing content (see also *Vector* 1997, Issue 7).

Check your progress to the landing site and make any appropriate adjustments.

Downwind Checks

Downwind checks (BUMPFH) need to be completed before landing. Apart from being the normal pre-landing checks, they act as a reminder to check that everyone's harness is tight and to think

about when hatches or doors should be unlocked. BUMPFH checks also provide a cue to consider when to put the undercarriage down. Leave the undercarriage 'UP', however, until you are certain of reaching your landing site.

By now you should be approaching the 1000-foot area that you selected. If too high, then shallow S-turns can be made to bleed off the extra height. If too low, you will need to consider flying a closer base leg (see diagram).

Final Actions

The final actions are to carry out the 'off checks' and to land the aircraft using techniques that will produce the best possible result. It is extremely important that you do arrive overhead the 1000-foot area as accurately as possible. This will then set you up for a fairly normal type of landing approach. Refer to *Vector* 1998, Issue 3 for details of 'off checks' – alternatively consult your instructor or pilot briefing notes.

Judging Your Final Approach

After having completed the 'off checks' it is possible then to focus totally on judging the base leg and final approach to your aiming point. Note that the 'off checks' can be carried out before turning onto a base leg (ie, during the downwind leg) so that your full attention can be given to judging the approach. It is extremely important that you **do not**

extend downwind (especially in strong wind conditions) or you will run the risk of undershooting the landing site. It is better to fly a slightly wider base leg and use it to adjust your height as required. This can be achieved by turning slightly away from the landing site if too high, or turning towards the landing site if too low. This means that at no time are you committed to a final approach where there is insufficient space to control your height (see diagram).

Note that final approaches directly into strong wind will mean low groundspeed and thus require greater judgement – otherwise an undershoot of the landing site may result. In very strong headwind situations, it may be worth considering flying faster than the aircraft's best glide speed to avoid an undershoot. On the other hand however, light wind conditions can result in ending up too high. The use of flap, side-slipping (if approved for your aircraft type or S-turns are all effective ways of bleeding off extra height – but flap should not be selected too early.

When you are absolutely certain that you can achieve your aiming point, then you can use flap (or sideslip if permitted) to touch down earlier than your aiming point. If necessary, touchdown can now be attempted as close to the threshold as possible.

Landing the Aircraft

There are several recommended techniques that can maximise your chances of a successful landing. Assuming that you have chosen a reasonable landing site, there is no reason why you can't put the aircraft on the ground intact. Refer to Vector 1998, Issue 3 for details on suggested techniques for landing an aircraft in a confined area – alternatively consult your instructor or pilot briefing notes.

Difficult Terrain

So far we have dealt with basic forced-landing techniques over an area that offers reasonable forced-landing possibilities. But what happens when you are faced with less favourable options? You may have been in situations, flying over rough terrain, where you have thought "what would I do if the engine failed now?" Your answer may not always be one which would provide a 'plan of attack' that will achieve a successful outcome.

When faced with an engine failure over such uninviting areas, there are several

other FLWOP techniques that can be applied to help improve your chances of survival. These are discussed below.

Bush-Covered Areas

Although a landing into trees is not an attractive option, it is a survivable one. Landing in trees should never be ruled out as an option, because it may be better than other areas of very rough terrain. The following general guidelines should improve the odds of surviving:

- Use the normal approach configuration – full flap and landing gear down.
- Keep the groundspeed as low as possible by heading into wind. Using the movement in the tops of trees will help to determine the wind direction.
- Manoeuvre towards areas of bush that contain as few large trees as possible – this will reduce the chances of contacting a large tree trunk. Low, closely spaced trees, with wide dense crowns (branches) close to the ground are much better than tall trees with thin tops – this reduces the free-fall to the ground afterwards.
- Make contact with the tree foliage at the minimum possible airspeed, taking care not to stall, and aim to 'hang' the aircraft in the tree branches in a nose-high attitude. This helps to preserve the cockpit area by allowing the underside of the fuselage and wings to absorb much of the initial impact energy.

Mountainous Terrain

A landing in mountainous terrain is probably the most difficult a pilot can be faced with. Flying over large areas of mountainous terrain should be avoided, where possible, to reduce the probability

option. It will depend on how tortuous is the valley or riverbed. It may be the best option when the valley sides are heavily wooded compared with more open parts on the valley floor.

- The top of mountain ridges can provide useful landing sites as they are often reasonably wide, may have less rock out-crops, and are more likely to be of a constant gradient. Ridge-top landings also make it easier to assess wind direction (something that can be very difficult to do in the mountains) – as opposed to valley landing sites where the wind tends to be multi-directional.
- Landing on a ridge line will also mean that ELT transmissions are more likely to be received than from landing sites lower in the valley. Your aircraft will also be more visible to Search and Rescue. The one disadvantage with landing on a ridge line is that temperature and wind-chill will be less favourable to survival.
- Try to avoid sites that have particularly large rock out-crops or drop-offs. These may become difficult to manoeuvre around if the approach and landing are misjudged.
- A landing site should be selected that allows an up-slope landing.
- When landing on a pronounced up-slope, care should be taken to ensure that enough speed can be maintained to change the aircraft's descending flight-path, just before touchdown, to match that of the slope. Note that it is possible to land an aircraft successfully on relatively steep slopes if enough speed is maintained.

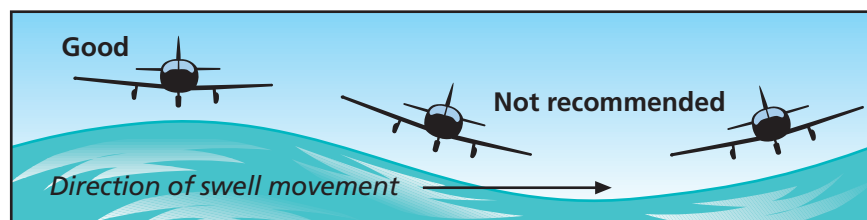

A ditching should be made along the crest of the swell when faced with large swell conditions.

of ending up in such a situation. Try to plan alternative routes that take your flight-path away from large expanses of mountains, or fly at a higher altitude to give yourself more time in the event of an engine failure – even it means adding extra time onto the flight. The following points should help to improve your chances of survival:

- Valleys and riverbeds are often a good

Ditching

Assuming that you have a choice, a well executed water landing – ditching – such as onto a lake or along a coastline, can provide less deceleration than a touchdown on rough terrain or into trees. Many pilots are reluctant to ditch, even though this might be a better option than the land-based alternatives. This is probably because of the fear of becoming trapped

Continued over...

in the aircraft and the fact that it will, more than likely, be lost. An aircraft that has been set down on the water at minimum speed, and remains intact, may float for several minutes. The buoyancy provided by air trapped inside of the wing (eg, fuel tanks) and fuselage will probably allow sufficient time to vacate the aircraft, and this will apply even with high-wing aircraft.

If you have a choice between a ditching and a forced landing, you should consider the following factors:

- The water temperature. Survival times may not be very long in the sea or a cold alpine lake. If you know the water to be extremely cold, then it may be wise to avoid ditching altogether.
- The proximity of the ditching area to land.
- How well your passengers can swim, and if there are enough lifejackets to go around – this is something that should be checked before the flight.
- Swell condition and the surface wind direction – it is generally not advisable to ditch in very rough swell conditions.

If the above factors are favourable, then ditching may be the best option.

Whether ditching by choice – or by having no alternative – the following techniques should be applied:

- Retractable landing gear should be kept up to provide the least drag in the water. This should prevent the aircraft from nosing over.
- Ensure that all occupants have their harnesses tight – you do not want anyone to be knocked out during the ditching for fear they may drown. Note that lifejackets can be donned during the descent, if there is time, but should be inflated only when clear of the aircraft.
- Avoid using full flap on a low-wing aircraft, as it will cause excessive drag under the water line and possibly result in an asymmetric failure of the flaps and slewing of the aircraft.
- Except when the water surface is relatively smooth – in which case a normal into-wind touchdown can be made – the ditching direction should be determined by the major swell system, rather than by wind direction. The danger of nosing into a swell is generally greater than that involved in ditching with a crosswind. It is best to aim for the crest of the swell and land along it. Note that with very strong wind conditions (ie, over 35

knots) it is better to plan the approach back into wind, as this will probably outweigh the danger posed by the swell system.

- It should be noted that depth perception can be difficult – or impossible – when landing on smooth water. There is a risk either of flying into the water, or of stalling at some height above the water and nosing-in. To minimise this hazard, set up the approach at minimum rate of descent – and be prepared not to realise exactly when you are going to hit the water.



This Cessna 185 remained afloat for 15 minutes after a successful touchdown.

Landing on Snow

A landing on snow should be executed like a ditching, with the same aircraft configuration (except that low-wing aircraft should use full flap), and the same regard for the loss of depth perception. While landing on snow can provide a cushioning effect, it can also hide dangerous obstructions with a light covering of snow. A snow covering will also make it more difficult to judge the surface gradient and general topography of the landing area. Try to avoid areas where there might be patches of ice, as these will cause the aircraft to slide for much greater distances, increasing the chances of colliding with a solid object.

Built-Up Areas

An engine failure while flying over a built-up area is somewhat more complicated as it generally involves the safety of people below. Civil Aviation Rule 91.311 requires that you **must not** fly over a built-up area at less than 1000 feet above the highest obstacle present (when operating within a 2000 foot horizontal radius of it) and that you **must always** remain within gliding distance of a suitable emergency landing site. With this in mind, you should avoid flying over built-up areas that do not have favourable emergency landing options and also resist the temptation to operate at heights where you are unable to glide clear – its not worth the risk. Get to know the forced-landing possibilities around your

city before going flying.

If you do find yourself facing an engine failure while operating over a large built-up area, turn immediately towards a known emergency landing area, eg, a park, a golf course or school grounds (note that it is your responsibility as pilot in command to consider the safety of people on the ground when making this selection). If this is not a favourable option, then a motorway which has double-lane traffic will allow you to touch down moving in the same direction as the traffic. It will also help you to pick a space between moving traffic more easily. If none of these options are available to you, then try to find any other open space where you will pose the least amount of danger to people on the ground.

Summary

The FLWOP has always been an important part of pilot licence training. For many of us, these forced-landing skills may have diminished slightly over the years. It is therefore important that we remain familiar with them. Being totally familiar with the FLWOP drills not only allows you make the most appropriate landing site selection, but also means that you can **concentrate on the task of successfully flying the aircraft** to that site. This sort of familiarity allows you to focus your attention **outside the cockpit**, where it should be, and reduces the tendency of becoming distracted inside the cockpit.

Minimise the time you spend flying over extensive areas of inhospitable mountainous terrain, large expanses of water, large areas of bush, and substantial urban areas. It is not worth taking the risk when an alternative route is available. The extra time and cost involved in selecting a safer alternative route, or higher altitude, is often not as much as you might expect.

Probably the best piece of advice that this article can give on a FLWOP is to always have a plan. This involves being aware of the wind direction, ground elevation, and possible landing sites below you. It involves knowing – as you are flying along – how you would execute an approach to them. The rougher the terrain, the more you need to carry out this assessment. The more you can ask yourself the question “what would I do if the engine failed now”, the better prepared you will be to respond quickly if it ever happens to you. ■

Aerodrome Markings – A Guide

You should be as familiar with airport ground markings as you are with highway traffic signs – not knowing what they represent could lead to a dangerous situation. The following article should provide a timely refreshment of that knowledge. The topic is also covered in our video *On the Ground*, which can be borrowed from the CAA Library or purchased from Dove Video.

For the general aviation pilot with little experience in operating from busy aerodromes, negotiating the concrete and asphalt maze of taxiways, turnoffs, holding points, apron areas, etc, can be rather bewildering.

A wrong turn at the wrong time may be not only very embarrassing but also potentially hazardous.

It is very important for all pilots using such aerodromes to be thoroughly familiar with standard ground markings, as well as the layout of the manoeuvring area and ground movement procedures. Ground movement charts for the major aerodromes and a number of provincial airports are provided in the IFG and VFG. Taxiing instructions or guidance given at controlled aerodromes may not protect you against confusion or jeopardy if you cannot interpret and follow the appropriate markings.

Large aerodromes with interconnecting taxiways are designed for speedy, efficient movement and safe traffic flow on the ground. To avoid becoming a bottleneck in the flow you can arm yourself with a little foreknowledge of the meaning of these ‘traffic signs’ by studying the diagrams included in this article. While these do not include all possible markings, those depicted should provide an adequate guide for the general aviation pilot. A detailed description and

explanation of airport markings may be found in the Aerodrome and Ground Aids (AGA) section of the NZAIP *Planning Manual* and in Advisory Circulars 139-07A and 139-06A.

Permanently and Temporarily Displaced Thresholds

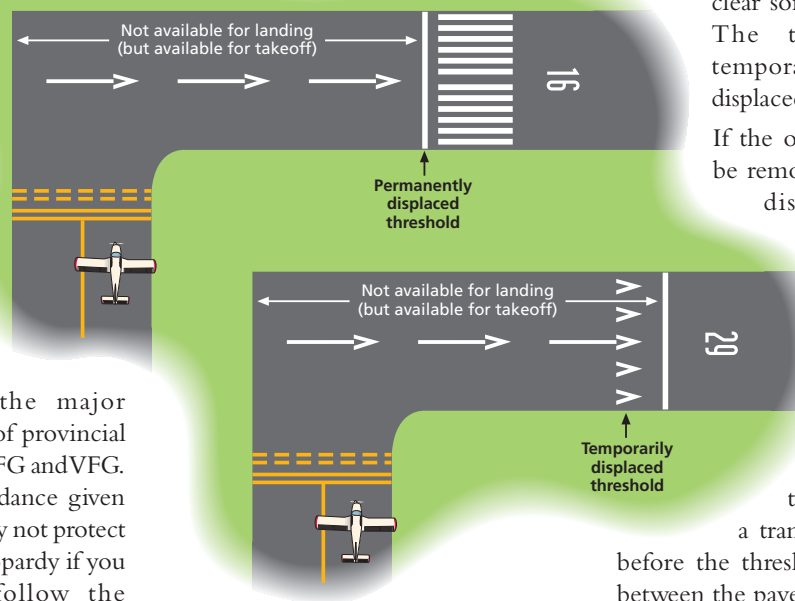

in length across the width of the runway, commencing at a point 6 metres from the runway end.

Displaced Landing Threshold

When necessary, the landing threshold will be displaced to a point along the runway where the approach profile will allow an aircraft to clear some particular obstacle. The threshold may be temporarily or permanently displaced.

If the obstacle will eventually be removed, then a *temporarily* displaced threshold is marked either by wing bars, cones, or marker boards placed outside the runway edge.

If the obstacle can not be removed, a *permanently* displaced threshold is marked by a transverse stripe 6 metres

before the threshold marking. Arrows between the paved runway end and the transverse stripe are located at a fixed distance back from the threshold stripes (see diagrams for details). Examples of aerodromes that have permanently displaced thresholds are Ardmore, Greymouth, Paraparaumu, and Wellington.

Aircraft should not touch down before the displaced landing threshold when landing and should be flown to cross the threshold markings at approximately 50 feet above ground level (see diagram below).

Continued over...

Runway Markings

All runway surface markings are painted white, sometimes edged with black (on concrete runways) to provide better definition. At the intersection of two paved runways, markings on the primary runway only are displayed.

Threshold Markings

Threshold markings are provided on all paved runways. They comprise a series of parallel, longitudinal stripes 30 metres



... continued from previous page

It must be emphasised that a displaced landing threshold **is not a displaced takeoff threshold**. It has nothing to do with the point for commencing the takeoff roll. Indeed, failure to use the full takeoff distance available could result in the aircraft having an inadequate takeoff distance available, with consequent reduction of obstacle clearance in the subsequent climb. But the runway available for takeoff in the **opposite direction may be shortened** because of obstacles associated with this displaced threshold (see diagram on previous page).

Centreline Markings

Centreline markings are provided on each paved runway, commencing from the runway designation marking. The centreline consists of a series of uniformly spaced lines and gaps along the centre of the runway throughout its length.

Runway Designation

The runway designation is located just beyond the threshold marking of each paved runway; it consists of the first two digits of a magnetic bearing relating to the runway centreline. For example, if the runway centreline is 286 degrees magnetic, the runway designation will be 29 – the nearest first-two digits.

Fixed Distance Markers

Fixed distance markings consist of a rectangular block on each side of the runway centreline, 300 metres from the threshold. Each rectangular block is composed of a series of thin longitudinal stripes. This is where you should aim to touch down; it works on the assumption that you pass over the runway threshold at a height of 50 feet.

Touchdown Zone Marking

Touchdown zone markings are provided on runways having instrument approaches and consist of some pairs of rectangular blocks at 150-metre intervals from the threshold. They provide reference points for a pilot to assess their progress towards the fixed distance markers.

Touchdown Zone Limit Marking

Triangular touchdown zone limit markers are provided at some aerodromes as 'go-around points' for specific types of heavy aircraft which are runway restricted. The marking consists of a series of transverse stripes in a right angle pattern located at the runway edges.

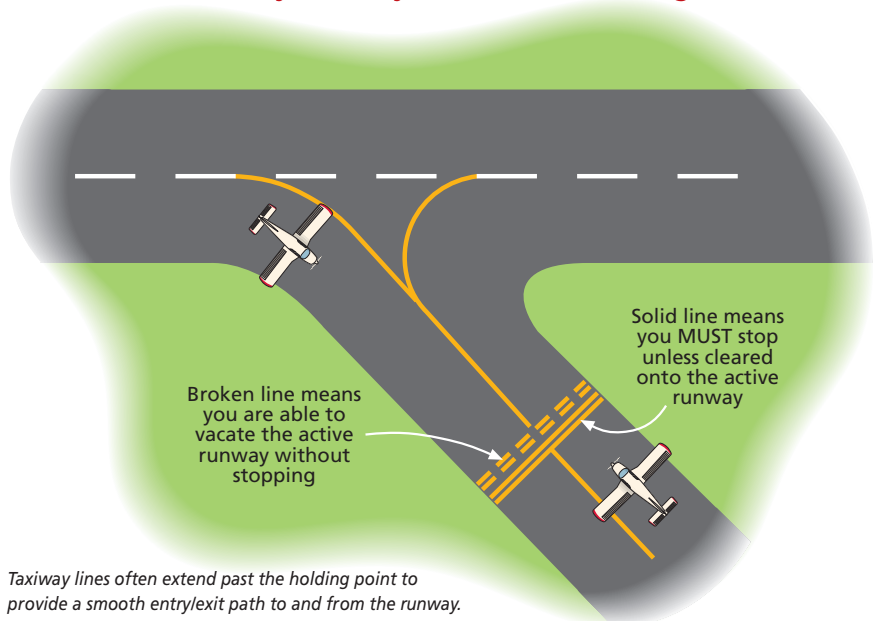

Taxiway lines often extend past the holding point to provide a smooth entry/exit path to and from the runway.

They are applicable only to those specific aircraft types. An example would be for a 747 using an aerodrome such as Wellington.

Taxiway and Apron Markings

Taxiway and apron markings are of a conspicuous colour (normally yellow) which contrasts with the colour used for runway markings – they may also be edged in black to provide better definition.

Taxiway Holding Point Marking

A taxiway holding point marking is painted as a stop line to give adequate separation from the active runway. Aircraft should not proceed beyond a taxiway holding position in the direction of the runway until cleared to do so by air traffic control. These markings consist of transverse lines across the width of the taxiway. Note that the line nearest the runway is broken and the one on the taxiway side is solid.

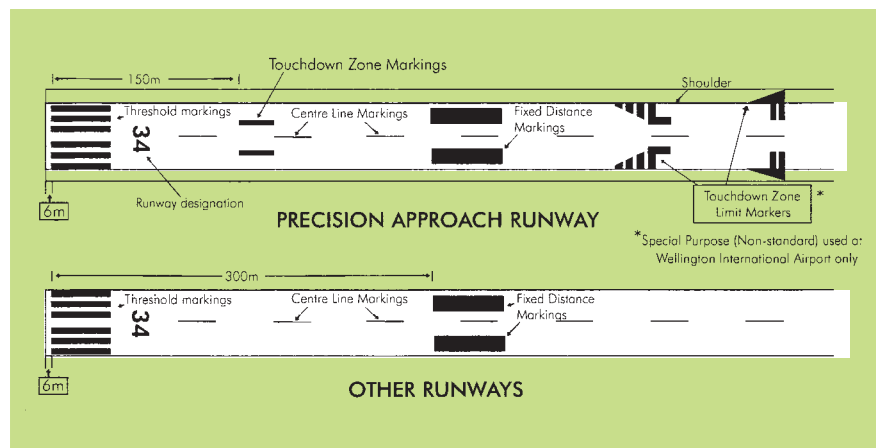

Taxiway Centreline Marking

A taxiway centreline marking is a continuous line. On a taxiway curve the centreline marking will continue from the straight portion(s) of the taxiway at a constant distance from the outside edge of the curve. It is important that taxiway lines are followed when manoeuvring around the aerodrome to ensure adequate wing clearance in the case of large aircraft. Make sure that the 'right of way rules' are observed – ie, you should move to the righthand side of the taxiway line when another aircraft is approaching you.

Closed Taxiway/Runway Marking

If a runway or taxiway (or a portion of either) is closed, white crosses near the ends of the closed portion will be painted or will be formed by white marker boards.

Marker Boards or Cones

Marker boards or cones displayed on an aerodrome indicate the safe limits of aircraft movement. They comprise distinctive rectangular boards or pointed cones, coloured white, red, yellow or orange, and they are displayed on the boundaries of the areas concerned. ■

Avoid that wire strike!

Wires and wire marking are a topical subject at the moment, with a recent Discussion Paper on the marking and/or charting of aerial wires as a means of assisting in the prevention of wirestrike accidents.

Another essential tool in avoiding wirestrike accidents is the training of pilots. The CAA and Trans Power New Zealand Ltd, with the assistance of the Aviation Industry Association, are sponsoring several Wirestrike Avoidance Training Seminars to be held in July.

The first seminar will be held during the Aviation Industry Association Conference in Auckland and is scheduled for Thursday 23 July from 0900 to 1230. Further seminars will be held in Palmerston North on Friday 24 July, and in Christchurch on Saturday 25 July, both from 0930 to 1300. There is no attendance fee.

There have been 67 wirestrike accidents in New Zealand since 1978 in which 33 lives have been lost, and a further 30 people were seriously injured. Wire strikes continue to be one of the most devastating accidents for professional pilots and crews whose job requires them to fly in the low-level wire environment. Perhaps the greatest tragedy is that the vast majority of these accidents are entirely preventable. One of the common root causes of wirestrike accidents is the crew's lack of understanding of the specialised skill needed to operate an aircraft in the vicinity of wires.

This seminar has been specifically designed for professional pilots and crews whose missions require them to operate in wire infested environments. It is a

derivative of a two-day course taught at HELI-EXPO (in the USA), designed to train utility patrol crews in how to operate safely on powerline patrol. Its acclaimed methods for early detection of wires and avoiding wire strikes fill a definite void in most low-level flight training programmes. Aviation professionals learn about the specialised skills needed to fly in the wire environment and acquire the knowledge to help them forecast the presence of wires before they can actually be seen.



Topics covered will include:

- Why the wire environment continually takes such a serious toll on aircraft and crews.
- How a proactive approach to wire strike avoidance will save lives, aircraft, and your business.
- How to determine where the wire environment really is.
- What professional powerline patrol crews call the *speciality skills* involved in forecasting the presence of wire before you can see it.
- How knowledge of the dynamics of the wire environment creates the

applied situational awareness necessary for low-level flight operations.

- Knowledge of the various wire systems and components common to the wire environment and their unique dangers.
- The *invisibility equation*. What makes wire invisible, and how to detect it?
- How to keep from being fooled by the *optical illusions* caused by wire.
- Value of crew resource management to the low-level flight operation.
- The true cost of a wire strike. Why wire strikes often put operators out of business.
- Other low-level hazards found exclusively in the low-level wire environment.
- Safe guidelines for flight in the wire environment.
- Night operations in the wire environment.
- Techniques for flying neighbourly, and noise abatement.
- Additional topics which are of paramount importance to low-level helicopter operations.

Who should attend?

All professional pilots and operational crew whose mission profiles require them to enter or operate in the wire environment. This includes:

- Ops Managers, Chief Pilots responsible for low-level flight operations.
- Agricultural pilots (fixed-wing and helicopter).
- Military pilots.
- Search and Rescue pilots and crews.

Continued over...

- Emergency Medical Services pilots and crews.
- Police pilots and crews.
- Specialist pipeline and powerline observers.
- Television and news-gathering pilots and crews.
- Helicopter flight training organisations.

The seminars will be presented by Robert Feerst, President of Utilities/Aviation Specialists, Inc, based in Indiana USA, a company which specialises in technical advice, training and operations management services to pipeline, power

and telecommunications companies which employ helicopters in their daily operations. Robert is also Chairman of the Utilities Patrol and Construction Committee of Helicopter Association International. He combines 30 years of aviation experience with 26 years of operating in a joint gas and electric utility. He has been involved in wirestrike avoidance training for a number of years, and we have received very positive comment on the training given.

Don't miss this opportunity to hear an experienced and respected speaker. If you fit into any of the above categories, you are urged to attend one of the seminars.

Thursday, 23 July

Auckland, AIA Conference, Sheraton Auckland, Cnr Symonds St and City Road
0900 to 1230

Friday, 24 July

Palmerston North, Quality Hotel Palmerston North, 110 Fitzherbert Ave
0930 to 1300

Saturday, 25 July

Christchurch, Airport Plaza, Corner Memorial Avenue and Orchard Road
0930 to 1300 ■

GAPs in Your Knowledge?

Ever thought that there should be a place where the collective knowledge from the old hands should be collected and made available to the rest of us? Some of it soon will be.

The CAA is about to launch a new safety education series called GAPs – for **Good Aviation Practice**.

GAPs will cover a wide variety of topics, from airspace to aeroplane performance, from wake turbulence to wire strikes. They will be the best information and advice that we can offer. These small booklets will be available free of charge, and we hope that you will like them so much that you will collect them and regularly refer to them. You could look on them as permanent copies of the best of *Vector* (although topics won't be limited to what has appeared in *Vector*).

Initial distribution will be via participating training organisations and CAA's Field Safety Advisers – **but don't call anyone yet**. We'll advise in *Vector* when titles become available.

Improved National Briefing Office Services

The following article has been prepared by John McKenzie and his staff at the National Briefing Office (NBO). It provides details on the improved flight-planning services that the NBO offers pilots.

In the last few years, demand for NBO services has grown markedly. Airways Corporation has introduced a number of new technologies that place an emphasis on providing customers with alternative means of accessing both weather and NOTAM information. Current services available to pilots wishing to access such information include the free-phone number 0800 654 957 and DATEL (Data Telephone). DATEL permits customers to access weather and NOTAM data from the Aeronautical Database via their home computer and modem. For more information contact Colin Brown on 0-3-358 1666.

The 0800 654 957 freephone number gives access to both Fax-On-Demand and NBO operators. Fax-On-Demand permits customers to access weather and NOTAM information via a touch-tone phone delivered to a nominated fax machine. You will need to register with Airways Corporation to access Fax-On-Demand. For an application form, fax Susan Edmonds on 0-3-358 2790. Fax-On-Demand customers are reminded that information delivered via fax is subject to network congestion like any other telephone line. Non-receipt of information within 15 minutes should be viewed as being within this category and a further request made.

The NBO has four lines dedicated to the 0800 654 957 number for customers to make personal requests for weather and NOTAM information. This can be supplied verbally or directed to a fax machine or a teleprinter

at other ATS units. These lines are also used for filing flight plans, some IFR clearance delivery services, and other general aviation enquires. We encourage customers to use electronic services such as DATEL and Fax-On-Demand to leave NBO operators more time to manage their other duties.

As well as the technologies described above, the NBO has introduced new methods for processing flight plans. NBO operators now input flight plans directly into the computer system, enabling immediate processing and delivery of this information to the pertinent units – thereby significantly reducing handling time. Customers are reminded that they need to provide their flight-plan data in the correct order so that flight-plan processing may be done as efficiently as possible.

Standard Plans have been created for both IFR and VFR customers, permitting rapid filing and processing for both the customer and Airways staff. Information on these is available by phoning 0-3-358 1622.

The NBO is staffed on a 24-hour basis. The number of operators on at any one time is based on historic demand trends, with up to four positions being available. However, there will always be occasions when the demand exceeds the available resources – delays may be experienced if this occurs.

We are working towards improving our flight-plan processing times to enable us to handle more calls within a given time period. The alternative mediums made available to customers to access information are helping us achieve this. Hopefully, by working together, we can provide all customer services in a timely manner with a minimum of delay. ■

The following article deals with all the important points that make a taildragger different to a nosewheel aircraft and how this affects the skills and techniques necessary to master the taildragger when near the ground. The text comes straight out of Barry Schiff's book, *The Proficient Pilot*, Volume 1, and Barry has kindly given us permission to reproduce it.



Flying a Taildragger

Photo by Dave Bates New Zealand Wings Magazine

Until the advent of jet propulsion, almost all military fighters were taildraggers – for a good reason. A raised nose was required to provide ground clearance for the huge propeller. There were, of course, some notable exceptions such as the Bell P-39 Airacobra and Lockheed P-38 Lightning, but the taildragger reigned supreme.

General aviation really did not utilise the nosewheel until the late 1940s and early 1950s. Among the first to sprout tricycle 'training wheels' was the Ercoupe (1946). It was followed by the classic Beech Model 35 Bonanza (1947), Piper's flying 'milk stool', the Tri-Pacer (1951), and Cessna's venerable model 172 Skyhawk (1956). The nosewheel became extremely popular because it is an easier, more forgiving method of manoeuvring an aeroplane on the ground. Cessna was so enthused that it referred to its 172 as having 'Land-O-Matic' landing gear. Although that was an obvious exaggeration, even the stalwart champions of conventional gear (which has become a modern-day misnomer) had to admit with nostalgic regret that this claim contained a certain element of truth.

It was anticipated that the tailwheel would become as anachronistic as the horse and buggy, but to the surprise of most and the delight of others, the tailwheel survives. Taildraggers still are being manufactured because they are ideally suited for certain special purposes. Bush pilots, for example, know that, in addition to offering greater propeller

clearance, the tailwheel allows taxiing turns in tight quarters because the aeroplane can be pivoted on one main tyre (this normally should be avoided, however, because such abuse can wear flat spots on a tyre). Also, a tailwheel weighs less than a nosewheel, creates less drag, and is less expensive to manufacture, replace, and maintain. Some people even contend that a taildragger has better short-field performance than an identical aeroplane with a nosewheel. Although some might disagree with this, the claim is accurate.

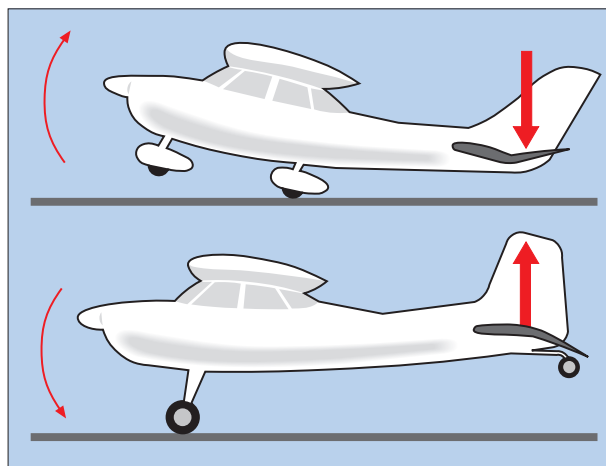

Figure 1. Lift forces of the tail surfaces in nosewheel vs tailwheel aircraft.

Figure 1 shows a 'trike' and a conventional aircraft being rotated for takeoff. Notice that the horizontal tail surfaces produce a downward force to raise the nosewheel. This 'negative lift' effectively adds weight to the aeroplane and requires the wing to produce additional lift for takeoff.

But look at the taildragger. The horizontal tail surfaces produce an upward force (positive lift) to raise the

tail. Since the tail-feathers support some aircraft weight, the wing does not have to produce as much additional lift to get the aeroplane off the ground. In other words, the taildragger requires slightly less airspeed for takeoff than does a trike.

The taildragger also is best suited for unimproved and soft-field operations. This is because the tailwheel usually can be lifted quite early in the takeoff roll, and the wing can be set at the maximum lifting angle, poising the aeroplane for flight very early in the game.

The nosewheel, on the other hand, cannot be raised until the aircraft achieves a faster speed. As a result, the nosewheel follows the irregular terrain like a cartographer's pen. This causes the aeroplane to bobble along the ground and the wing's angle of attack to vary considerably during the takeoff roll. Consequently, acceleration is impeded.

A common mistake made by new taildragger pilots is raising the tail too high during takeoff. This can set the wing at a negative angle of attack and drive the main landing gear harder onto the ground. The increased tyre friction created, along with the additional drag produced by such a tail-high attitude, retards acceleration considerably. Such an improper technique can even prevent some low-powered taildraggers at high density altitude from ever reaching liftoff speed.

The nemesis of the novice taildragger pilot is directional control.

Continued over...

... continued from previous page

There are two reasons for this. First, the taildragger is a marvellous weather vane, especially if equipped with a fully swivelling tailwheel. Consequently, considerable attention must be paid to the machine whenever in motion on the ground. Some instructors (of which there now are very few schooled in the fine art of taildragging) advise students to constantly and gingerly 'walk' or 'fan' the rudder pedals while taxiing. Presumably, this prevents the pilot's feet from falling asleep at the controls and allowing the aircraft to wander off track. Once airborne, of course, there is essentially no difference between taildraggers and trikes.

Since taildraggers head into a strong wind like a horse heading for the barn, such an intentional turn while taxiing is simple; let go and the aeroplane almost turns itself.

“Steering a taildragger is like pushing a wheelbarrow; it always wants to veer to one side or the other.”

Turning the other way, downwind, can be very tricky (and even impossible) when the wind is blustery. The effort can require full rudder, hefty differential braking, and a heavy hand on the throttle (to blow air across the rudder and increase its effectiveness). Weathervaning is not a serious problem with other aeroplanes because a nosewheel resists being pushed to the side.

But weathervaning is only one reason why it can be difficult to keep a taildragger's nose pointed in the right direction. The second has to do with the location of the aircraft's centre of gravity (C of G) with respect to the main landing gear. Out of necessity, the C of G is behind the main gear; if this were not so, the beleaguered taildragger would simply and ungracefully plop on its nose.

Figure 2 shows a taildragger taxiing in a straight line and then swerving somewhat to the left, intentionally or otherwise. Notice that the C of G becomes positioned behind the right main wheel. Because of momentum (or inertia), the C of G tends to continue moving along its original path, which is straight ahead. In other words, the C of G (or the weight of the aeroplane itself) tends to continue

the turn by pushing against the outside wheel. In this respect, the taildragger is unstable. Once a turn on the ground has begun for any reason the aircraft tends to continue turning ...and turning ...and turning. Only the attentive pilot can reverse the process before the aeroplane eventually runs out of steam and slows to a halt.

On a trike this situation is reversed (Figure 3). To prevent the tail from striking the ground (as when the aft

baggage compartment is overloaded), the C of G must be forward of the main landing gear. This is convenient because it keeps the nosewheel on the ground where it belongs.

The stabilising effects of this arrangement are that once the aircraft has begun to swerve, the momentum of the aircraft (acting through the C of G) tends to pull forward on the inside wheel and straighten things out.

The difference between a taildragger and a trike is most easily understood by comparing these aircraft to the manipulation of a wheelbarrow. Steering a taildragger is like pushing a wheelbarrow; it always wants to veer to one side or the other. Manoeuvring a trike, however, is like pulling a wheelbarrow; it goes exactly where you want it to. Little wonder that the nosewheel has become so popular.

When the combined troublesome effects of weathervaning and C of G location are considered, it is easy to understand why pilots have developed a respect for taildraggers. Attention to directional control is critical. Otherwise the taildragger will bite when least expected. This behaviour can range from having the nose swap ends with the tail, to the infamous groundloop, a usually involuntary manoeuvre where the pilot becomes their own passenger. He or she then becomes helpless to do anything but survey the horizon as it streams rapidly across the windshield. Sound like an exaggeration? Believe me, it is not. The groundloop can punctuate the end of a flight with blurring, embarrassing finality.

The scenario for a groundloop usually begins with an improperly executed crosswind landing, or by an inattentive pilot taxiing sharply off the runway at high speed. The nose begins to swerve and, unless arrested, continues to yaw with a progressively shorter turning radius.

As the arc described by the aircraft begins to spiral inward, the rate of turn also increases. Physicists explain this phenomenon with a relatively fancy phrase – moment of inertia. Simply put, this means that as the radius of a revolving mass decreases, the rate of turn increases. A ballet dancer takes advantage of this by bringing their arms closer to their body (reducing the radius) to increase rotational velocity during a pirouette.

Pirouettes are lovely on dance floors and ice-skating arenas, but they are not

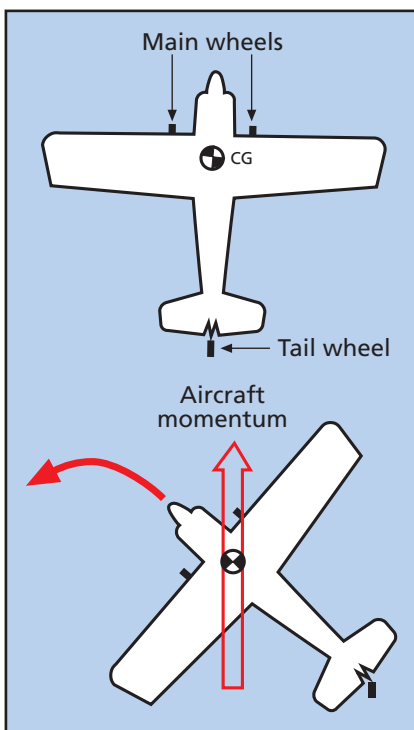

Figure 2. Directional instability of a taildragger.

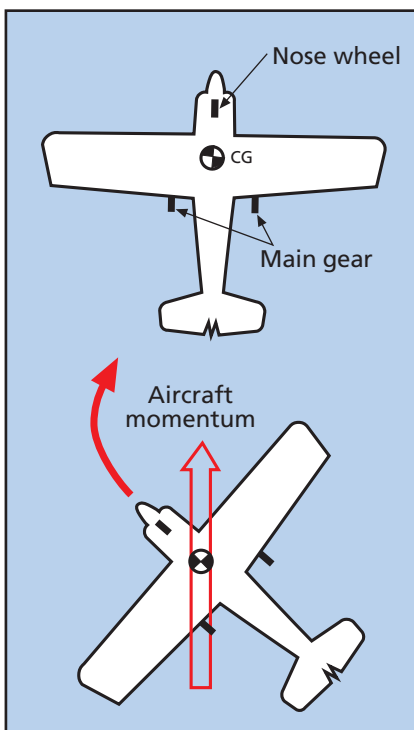

Figure 3. Directional stability of a nosewheel aeroplane.

graceful when performed by an aeroplane. Once the groundlooping process begins, turn radius continues to decrease, which quickens the rate of turn. Simultaneously, centrifugal force increases. Unless this whirling dervish is interrupted with some timely handling of flight controls and throttle, the aircraft ultimately loses balance and topples toward the outside wing. Although rarely injurious to those inside, the cost of repairing a wingtip and possibly a folded main gear can be substantial.

Fortunately, groundloops usually are not that difficult to avoid. Directional instability is a problem only to those who are inattentive or lack respect for that cute little wheel on the tail. In some respects, however, it is worth considering that a taildragger landing really is not complete until the aircraft has been parked, the wheels are chocked, and the pilot is at home with a cold drink in hand.

Another problem pilots have with taildraggers is bouncing during a landing attempt, a taildragger mannerism usually and erroneously attributed to spring-like landing gear. A bounce occurs because of improper landing technique; otherwise, pilots of Cessna 170s and early-model 172s, for example, would encounter similar bouncing difficulties because each has identical main landing-gear struts made of spring steel.

The bounce occurs in a taildragger primarily because of C of G location, and from not touching down in a three-point attitude (unfortunately, too many pilots have perfected three-point landings while flying nosewheel equipped aeroplanes, a skill not worth bragging about).

Notice that the upper aircraft in Figure 4 has been allowed to touch down prematurely, and the tailwheel is still off the ground. If the touchdown occurs with any significant sink rate, the momentum of the C of G (which is aft of the main gear) tends to push the tail farther down. But in the process, the nose rises, which increases the wing's angle of attack. As a result, additional lift is produced, causing an involuntary liftoff. The opposite occurs during landing in a trike. When the main wheels punch the concrete, the nose-heaviness of the aircraft forces the nosewheel down.

This is another reason why the trike is so much more tolerant of sloppy technique. Bounces do occur when flying a tricycle-gear aircraft and are usually caused when pilots apply excessive back pressure during a premature touchdown.

“A common mistake made by new taildragger pilots is raising the tail too high during takeoff.”

The key to a successful landing in a taildragger is to touch down without drifting (to preserve directional control) and in a three-point attitude (to prevent bouncing). If the tail wheel touches simultaneously with the main gear, or

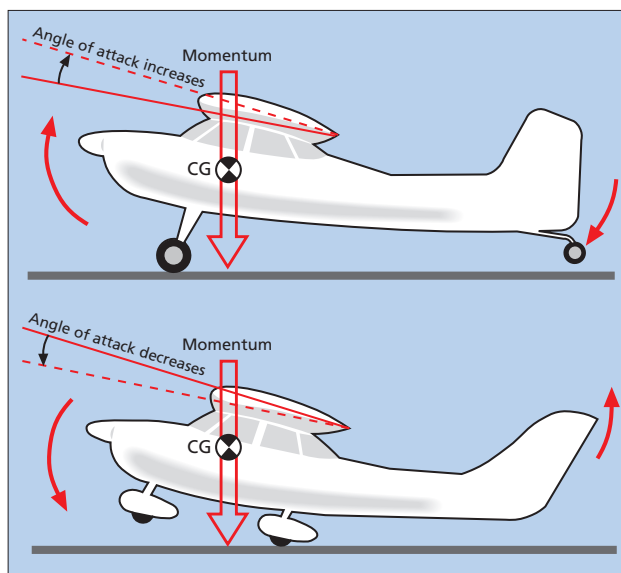

Figure 4. Effect of touchdown in a taildragger and nosewheel aeroplane.

slightly earlier, the angle of attack cannot be made to increase. Additionally, designers usually arrange for taildraggers to be virtually stalled when in the three-point attitude, a convenience that results in a minimal touchdown speed.

The ‘wheel landing’ is another method of reconnecting a taildragger with the ground. Although the manoeuvre is strangely named (it is hoped that all landplanes land on wheels), it is more aesthetically pleasing to observe and somewhat more difficult to perform than a conventional taildragger landing. The wheel landing is executed in a near-level attitude by literally flying the main wheels onto the runway. Although touchdown occurs at a faster airspeed than that of a three-point landing, the advantages include being able to land more precisely on a chosen spot, and

having better crosswind handling because of crisper control responses during touchdown at a higher speed.

There are two noteworthy forces at work during a wheel landing. The first is the tendency of a taildragger to bounce nose high, as previously discussed. The second is a nose-down pitching moment caused by the retarding frictional effects of the tires that occur at touchdown. The trick is to land in such a way as to balance these nose-up and nose-down forces. A delicate procedure. To ensure that the first is the only touchdown, it usually is necessary to add a bit of forward pressure on the control wheel (or stick). This is the difficult phase of a wheel landing for all new taildragger pilots (and some experienced ones). There is a fear of applying too much forward pressure and using the nose to dig a furrow in the runway. This anxiety generally is unfounded.

Although it is possible under certain extreme conditions to buzz-saw the runway with the propeller tips, this would require an extraordinary application of forward control pressure. In theory, it is impossible to actually nose over during touchdown. The force of the relative wind pushing against the top of the horizontal tail surfaces prevents the tail from being raised to such an exaggerated attitude –**but please don’t try it.** At slower speeds, and when taxiing into the wind, it is possible to nose over, but this usually requires using full forward elevator pressure, heavy braking, and some power.

The only other problem that often plagues new taildragger pilots (especially short ones) is restricted over-the-nose visibility while taxiing. This handicap, however, is easily overcome by slowly S-turning along the taxiway to maintain a watchful vigil for other traffic.

It can be said that flying a taildragger is more difficult than flying a trike. It is more of a challenge in the sense that it demands to be handled properly at all times. To fly a trike properly also can be demanding, but such an aircraft is more tolerant of errors made along the way.

In the final analysis, taildragging disciplines a pilot to fly well and attentively at all times when near the ground. Lessons all of us can use. ■

Mind Your Ps and Qs

Q-Code History

Ever wondered where QNH came from? What about QFE, QNE and QFF, and what do they mean?

From the small amount of research that *Vector* has been able to do, it seems that it originated in the days of morse-code transmission, where the use of standard questions served to cut down on message length. In today's environment of VHF radio communications and satellite links, its need has diminished – but some amateur radio operators still use it, especially for HF operations.

Asking for QDM would get you the magnetic bearing to the station from the answering station. Most of the codes were for posing questions and giving answers. For example:

QAN What is the surface wind and speed?

QBF Are you flying in cloud?

QRM Are you being interfered with?

QRN Are you troubled by static?

QTR What is the correct time?

QFR Does my landing gear appear damaged?

QRV Are you ready?

QFG Am I overhead?

Lastly, the all important –

QRC By what private enterprise (or State administration) are accounts for charges for your station settled?

Throughout the years there have been a number of “made-up” Q-codes such as:

QLF Try sending with your left foot.

QRB My trailing aerial is wound around a rainbow, and I am about to transmit in technicolour.

Q-Codes in Use Today

QNH must be the most common Q-code and has made its way into the language to become a ‘word’ in its own right. QNH really means, “What should I set on the subscale of my altimeter so that it would indicate the elevation of my aircraft if it were on the ground at your station?” Essentially this is the barometric pressure at the station reduced to mean sea level pressure using the International Standard Atmosphere (ISA) model. You should then have the elevation of the aerodrome above mean sea level showing on the altimeter when on the ground.

QFE is another common code that has made its way into everyday language. It means, “What should I set on the subscale of my altimeter so that it would indicate its height above the reference elevation being used?” You are using a QFE value when you set the altimeter to 0 feet when on the ground at an aerodrome (ie, the reference elevation).

QFF is seldom used, but it means, “What is the present atmospheric pressure converted to mean sea level in accordance with meteorological practice?” This is very similar to QNH, except that the conversion is done using the actual lapse rate for that day at that location. It is perhaps a little too complicated for its worth and thus has been dropped from use.

The other Q-code in use today is QNE which means, “What indication will my altimeter give on landing at (place) at ...

hours, my subscale being set to 1013.2 hPa?” Essentially this means set 1013.2 on the altimeter.

Contrary to popular belief, there is no correlation between the two letters after the Q and what they stood for. They are not an abbreviation, although there are some examples of it being very close to one.

QNH or QFE?

In New Zealand all aircraft flying within a QNH zone should be using the appropriate QNH setting. In the past, allowance was made for using QFE when carrying out an instrument approach, but QFE has been unused for the last 20 to 30 years. It was originally available on request by airline pilots who were doing precision approaches. As there is no longer the need for QFE, it has been eliminated from the Rules, from Part 91 in particular.

So what does Part 91 say you have to do?

“Each pilot of an aircraft shall maintain the cruising altitude or flight level of that aircraft by reference to an altimeter that is set:

- when operating at or above flight level 130, to 1013.2 hPa [QNE no less!]; and
- when operating at or below 11,000 feet, to the appropriate area or aerodrome QNH altimeter setting ...”
- when operating between 11,000 feet and flight level 130, as authorised by ATC.

QFE does still have a limited use for those people wanting to know their elevation above the aerodrome level, for accurate circuits for example. Its use should be limited to circuit traffic only – if you are going cross-country then set the area QNH. When starting the approach at your destination, set the aerodrome QNH if available.

For instrument approaches when there is no aerodrome QNH available, use a remote QNH, and apply a correcting factor by adding 5 feet to the MDA for every 1 NM in excess of 5 NM from the QNH source. For example, for an instrument approach at Wairoa using the Napier QNH you would add 150 feet to your MDA (the distance between the Wairoa and Napier is 35 NM, therefore $35 - 5 = 30 \times 5 = 150$). ■

Seat Twist Follow-Up

Following Ross St George's article on seat-bolt attachment failures, in *Vector* 1998, Issue 2, it has been noted that some engineers have devised innovative solutions as a ‘quick fix’ to such problems. While these ‘quick fixes’ may, on the surface, appear to be good ideas, we would like to point out that they are actually unapproved modifications. This type of unapproved modification may be accompanied by liability issues in the event of failure. It is essential that approval is obtained **before any modifications** to an aircraft are carried out.

Uncontrolled IFR



This article is aimed at the IFR pilot, but VFR pilots should find the information useful, especially if operating in uncontrolled airspace with IFR traffic. VFR pilots are particularly directed to the section on uncontrolled aerodromes.

Photo courtesy of New Zealand Wings

Planning

Any flight starts with the preparation. This is especially important if you have not been to your destination recently or you will be operating in an unfamiliar environment. Be prepared.

Check the Route

Part of your planning should be to check the route and its associated limitations. Look at the airspace you will be in, or not in, as the case may be. Leaving controlled airspace requires a definite change in thinking.

Radio Frequencies

Write down all the radio and the pilot activated lighting (PAL) frequencies on your flight log before you leave. There is nothing worse than descending into uncontrolled airspace and not knowing what the information frequency is, or even worse, not knowing the unattended frequency at your destination.

Approaches

Check the approaches to make sure that you can comply with any applicable minima or requirements. Brief the approaches well before you need to fly them. If you are familiar with them, when it comes to briefing yourself in flight you are well ahead.

Local Procedures

Find out if there are any local procedures that you need to comply with. The VFG is a good source of information, as are local operators.

Controlled Airspace Activation

Consider what time of day you will be

operating. Most control towers, and Ohakea radar centre, go off watch at night, and you may find that what was controlled airspace a few hours ago is now uncontrolled, or is airspace controlled by another ATC unit (such as Christchurch centre for the Ohakea UTA). There is also the possibility of a different unattended frequency and yet another frequency for the PAL system.

Operating in Radar-Controlled Airspace

Where a radar service is provided, the need for full position reports is unnecessary once you are identified. The controller will request position reports, if necessary, and separate IFR traffic as required.

“Operating in uncontrolled airspace increases your workload and stress, because now you have to be both pilot and controller.”

Do not let your guard down. You should be monitoring the frequency and listening out for other traffic. A ‘situational awareness’ disadvantage of transponders is that the position report has disappeared. It is much harder to build a mental picture of what the traffic is doing. This, however, should not preclude you from monitoring as far as possible what is going on.

Operating in Non-Radar-Controlled Airspace

When you are operating in non-radar airspace, the controller relies upon you to provide clear and accurate position reports in order to ensure your separation from other traffic – your position reports are a must.

Your radio calls must be precise and contain all the information in the one transmission. There should be no need to make two calls because you forgot to include the ETA at the end of your first call. Try the following mnemonic, PTA, ETA: Position – Time – Altitude – ETA. Any GPS should give you an ETA at next station. Your ETA is an essential piece of information for procedural controllers to have – it needs to be very accurate too. When asked to report distance or altitude, always give both distance **and** altitude; it will not be wasted.

The requirements for position reporting are contained in the AIP *Planning Manual* OPS Section. Make sure you are familiar with these, or take some time to refresh yourself.

Leaving Controlled Airspace

When you leave controlled airspace the radar controller will normally advise you that you are about to ‘vacate controlled airspace’. Heed this warning. As soon as you leave controlled airspace you are on your own. You now have sole responsibility for maintaining separation from traffic and terrain. Maintaining separation from terrain is the easy part, as long as you follow the track and approach and stick to the minima.

Continued over...

... continued from previous page

Separating yourself from other traffic, however, is not so easy.

You need to brief yourself well before entering uncontrolled airspace. Have the frequencies set and the approach briefed. All of your resource should be concentrated on managing your own separation and the procedural work.

Make a defined transition from controlled to uncontrolled, including the radio frequencies. Frequency changes need to be set up early, but remember to work one frequency at a time. Take full advantage of having two radio boxes for setting up and monitoring frequencies where possible. But don't get too far ahead of yourself.

There is a strong tendency to remain with the radar controller longer than you should. Change over frequencies at the right time. You should be on the same frequency as other traffic in order to be able to build a picture of what is going on in your airspace.

Operating in Uncontrolled Airspace

Operating in uncontrolled airspace increases your workload and stress, because now you have to be both pilot and controller. You also have to deal with pilots who do not speak your IFR language. Be prepared.

Communication

Communication is essential. Radio calls are very important in uncontrolled airspace. They are your only means of keeping separated from other traffic. Make sure that your calls are precise. Accurate position reports are a fundamental part of IFR in uncontrolled airspace.

“VFR pilots operating around aerodromes where IFR aircraft are on the approach need to be especially vigilant.”

The use of standard phraseology is a must. This is especially important when in uncontrolled airspace, where the possibility of confusion is high. Take some time to review both the phraseologies and the reporting requirements, and cement them into your memory.

Required IFR position reports are not enough when dealing with VFR traffic.

IFR terms mean nothing to the VFR pilot – even other IFR pilots may not know what a “Lake 1 Departure” is!

Add geographic references to the end of your radio calls. At a bare minimum “10 miles to the southeast at 3000 feet” will give other pilots a much better idea of your location than “established on the arc”.

Other Airspace

Be aware of what other airspace may be around you. Once you leave controlled airspace you will no longer be automatically kept clear of restricted or danger areas.

Some of the other airspace types you may encounter are mandatory broadcast zones, general aviation areas, aerodrome



traffic zones or parachute drop zones. Airspace information is contained on Visual Terminal Charts (VTCs), and it is recommended that you carry these as well as your IFR charts.

You should have a good mental picture of your location in relation to ground features, especially when making a visual approach, as well as at night, so the use of a VTC may be necessary.

Self Separation

Remaining clear of VFR traffic while in cloud is easy – you are in IMC, they shouldn't be. Remaining clear of other IFR traffic is **not** so easy.

As yet there are no self-separation standards, but the CAA Rules and Standards team will be working on developing some. Until then, let's look at what ATC apply, and then we will suggest some guidelines.

ATC Standards

Some basic ATC separations are:

- 5 DME horizontal separation when radar monitored.
- 20 DME horizontal separation when non-radar monitored.
- 1000 feet altitude separation.

When VMC

Get your eyes outside as soon as you can. If you can see the other aircraft you are not likely to hit it and are therefore separated.

When IMC

Separation is best worked out on a priority basis, and since there are no set standards, the following are some recommended practices to help:

- Communicate. When on approach, establish radio contact early with other traffic. You need accurate regular position reports from them, and they need reports from you.
- Accurate position reports will help build the important mental picture.
- The lower aircraft usually has the right of way over other aircraft wanting to do the same approach. This will depend on each aircraft's distance from, and speed to, the Nav-Aid. Faster aircraft may have priority over slower aircraft.
- Arrivals have priority over departures – this includes the need to allow for arrivals carrying out the missed approach.
- Remember that any deviation from standard procedures will only serve to confuse and endanger others.

Unattended Aerodromes

Be aware that at times there will be heavy VFR congestion around some aerodromes, and once you are visual you are still required to slot into the circuit pattern established by other traffic. Your flight is not over when you pop out of cloud and enter VMC – you still need to slot into the circuit.

In order to sequence well there needs to be flexibility by all. Smaller aircraft can be a lot more flexible than others that are operating at a minimum of 140 knots. Patience is always appreciated.

Approach Conditional Areas

Approach conditional areas (ACAs) are established in uncontrolled airspace around the approach to unattended aerodromes. They provide some ‘protection’ from other aircraft in the area, especially VFR aircraft. VFR aircraft must comply with increased minimum meteorological conditions (1000 feet vertical and one nautical mile horizontal distance from cloud) unless it can be confirmed that there are no IFR aircraft on an approach. VFR aircraft are advised to avoid the area if there is an aircraft on approach.

ACAs end within one nautical mile of the nearest runway threshold. There, class G airspace rules apply around the aerodrome – including the requirement under Part 91 to conform with, or avoid, the traffic pattern formed by other aircraft.

VFR Pilots – Position Reports

VFR pilots operating around aerodromes where IFR aircraft are on the approach need to be especially vigilant. IFR pilots on the approach and not in VMC have only their ears to work out your position. When you hear an aircraft call inbound or on the approach, reply with your own position. If you do not speak up then the IFR aircraft will assume that there is no traffic and may not have made allowance for the need to join the established circuit.

Report geographically. Distance and bearing from the airfield or nearest visual reporting point is the best. Be exact and not a wild guess. If there are no designated visual reporting points, use an obvious geographic point. If there are designated visual reporting points use them, not local variations. Remember, this IFR pilot may not know where “Jim’s Airstrip” is.

Take care to make **all** your radio calls,

not just the ones you remember. If the weather is marginal then IFR pilots will be descending to low levels close to the aerodrome, and the last thing anyone wants is to look up to see another aircraft dead ahead. They need to know of your presence.

“Your ETA is an essential piece of information for procedural controllers to have – it needs to be very accurate too.”

IFR Approach vs Runway in Use

At aerodromes that have instrument approaches (particularly where a circling approach is required for one or more runways), the IFR pilot must be aware of the likelihood of opposing VFR traffic. If an ACA is present, there is **some ‘protection’** from VFR aircraft in marginal conditions when an IFR approach is likely to be necessary. IFR pilots, particularly those on training flights in VMC, who are making an approach need to be aware of the likelihood of opposite direction VFR circuit traffic. The sight of an aircraft approaching head-on could be very disconcerting for the VFR pilot.

Pilots conducting an IFR approach in VMC to an uncontrolled aerodrome **must** conform with, or avoid, the aerodrome circuit pattern. Position reports such as “established on final approach” may not mean much to the VFR pilot who has no idea of the approach route (or minimum altitude) – additional position information (eg, distance and direction from airfield) is advisable for the benefit of the VFR traffic.

Termination of Flight Plan

You are required to terminate your flight plan **as soon as practicable** on completion of the flight. When landing at a controlled aerodrome your plan will be automatically terminated. Remember, when you are landing at an uncontrolled aerodrome you must contact an ATS unit and terminate your flight plan.

There has been confusion about the time-frame in which you need to terminate your flight plan. Many people have mistakenly thought that terminating

within 30 minutes of their last transmission to ATS would stave off the first Search and Rescue phase. This is not the case. The INCERFA phase of the Search and Rescue process will begin **15 minutes** after your ETA stated for destination aerodrome in your IFR flight plan. Remember, the Rule says terminate “as soon as practicable”.

Two simple ways of remembering to terminate are to contact the Flight Information Service either before you land or once you are on the ground, depending on the coverage. Otherwise call flight planning once you are safely on the ground – not while on short finals!

One suggestion is to make it part of your shutdown checks – “Avionics off, call flight planning”, whatever will help you remember. Another suggestion is to get an orange keyring with the “terminate your flight plan” message. These are available from your local CAA Field Safety Adviser. Also, reminder stickers are now available from ATC and the Field Safety Advisers; these can be put on doors, your flight bag, etc.

Conclusion

Single-pilot IFR is made even more stressful when operating unprepared and under stress. Do not let this be you. Prepare well, know your requirements when outside controlled airspace, and know what you are getting yourself into. ■

Field Safety Advisers

John Fogden

(North Island, north of line, and including, New Plymouth-Taupo-East Cape)
Ph: 0-9-424 7911
Fax: 0-9-424 7945
Mobile: 0-25-852 096
e-mail: fogdenj@caa.govt.nz

Ross St George

(North Island, south of line New Plymouth-Taupo-East Cape)
Ph: 0-6-353 7443
Fax: 0-6-353 3374
Mobile: 0-25-852 097
e-mail: stgeorger@caa.govt.nz

Murray Fowler

(South Island)
Ph: 0-3-349 8687
Fax: 0-3-349 5851
Mobile: 0-25-852 098
e-mail: fowlerm@caa.govt.nz

Owen Walker

(Maintenance, New Zealand-wide)
Mobile: 0-25-244 1425
e-mail: walkero@caa.govt.nz

“... a taildragger landing really is not complete until the aircraft has been parked, the wheels are chocked, and the pilot is at home with a cold drink in hand.”

